

## innoelectric CEC Platform

Highest power density with full charging flexibility



### HIGHLIGHTS

- On-board chargers with the highest power density in its class: ~2,0 kW/l
- High efficiency of at least 96%
- Compatible with almost all common energy grids in Europe, North America, China and Japan
- Full interoperability according to all major charging standards: IEC 61851, SAE J1772, DIN SPEC 70121 and ISO 15118-20
- Includes bidirectional charge mode (V2X)
- Developed and tested according to ECE r10 rev.6

### EV charging the most comfortable way

Experience the future of EV charging with our innovative 22kW Compact Efficient Charger platform. Designed for maximum power and convenience, this charger delivers exceptional performance without compromising on reliability. The innoelectric CEC combines the power electronics and the D3C communication module enabling AC and DC charging without the need for additional devices. This is based on the innoelectric concept, which requires only the integration of a single-unit solution for all charging functionalities on the customer side.

### Multitude of application

#### Use Cases for the CEC

- Heavy duty, construction and mining machinery
- Municipal and agricultural vehicles
- Light and heavy duty trucks
- Marine applications such as ferries and yachts
- Stationary and mobile applications such as refrigeration and energy storage systems



### AC and DC charging with one compact component

The innoelectric CEC is designed to meet the highest industry standards, offering both AC and DC charging in a single compact component. The charger supports AC charging based on the common international standards, ensuring reliable performance and compatibility across a wide range of electric vehicles. The CEC's distinguishing feature is its integrated charging communication controller, which enables DC charging as well. In addition, the CEC offers the bi-directional charging for V2X applications.

### Extended functionalities

Innoelectric develops its products in-house, from the hardware to the software, to ensure the highest quality and functionality. In light of the numerous projects we have undertaken and the evolving demands of our international customer base, we have taken the initiative to closely examine current trends and requirements.

Samples available now!

# innoelectric CEC

## Technical Drawing

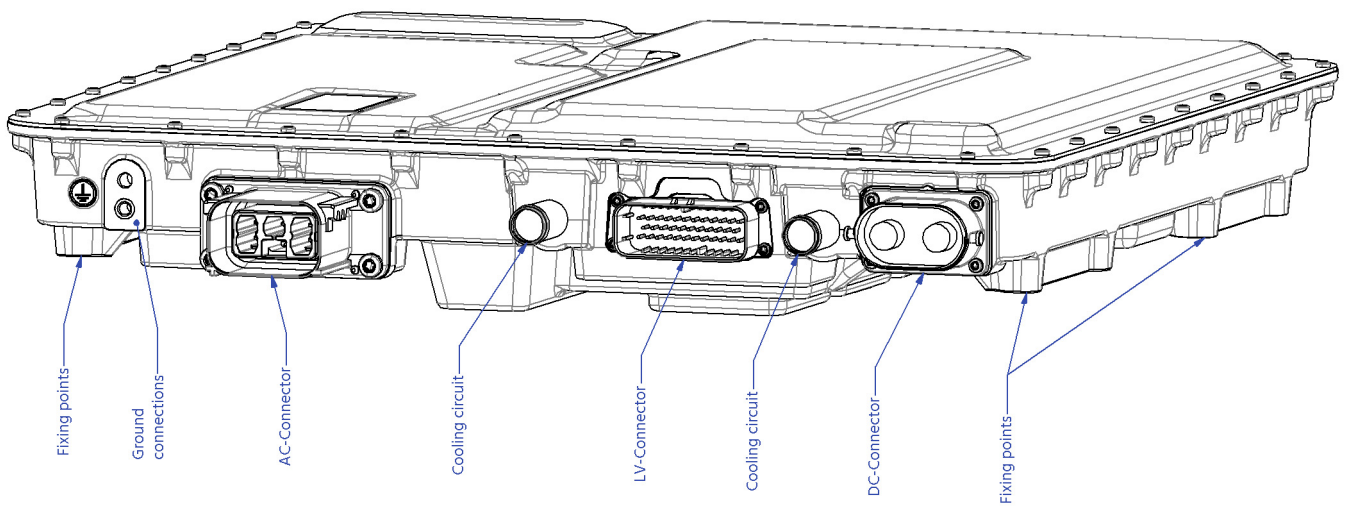
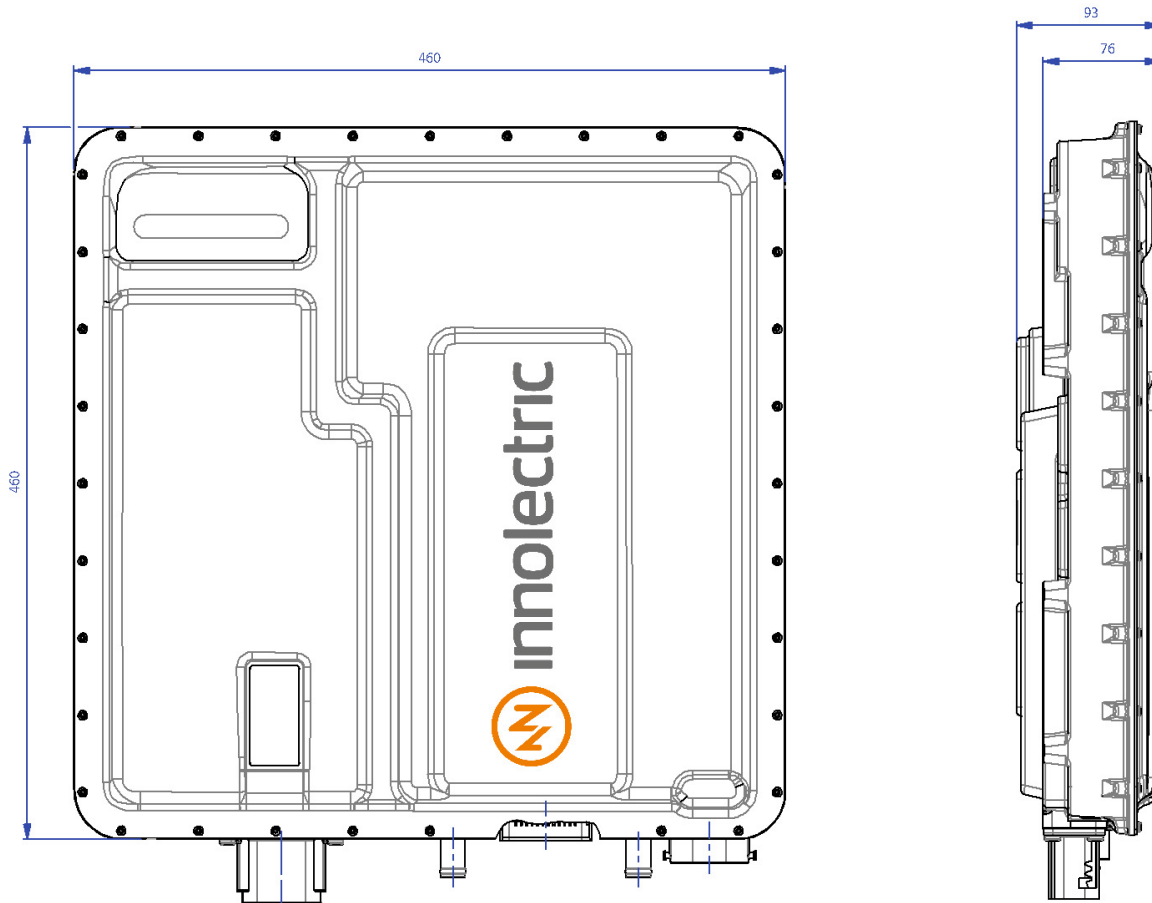

# innoelectric CEC

## Technical Data

### Components

	CEC-22400	CEC-22800
Component design	400 V	800 V
Input power	22 kW	

### AC Input

Input voltage (3~ AC)*	327 - 440 V
Input voltage (1~ AC)*	102 - 265 V
Input current	32 A (per phase)
Frequency	50 - 60 Hz (+ / - 1 %)
Efficiency	typically 96 %

### DC Output

Output voltage*	268 - 500 V	520 - 850 V
Output current*	up to 75 A	up to 45 A

### Charging communication

AC charging	IEC 61851, J1772 Type 1, Type 2, (NACS)
DC charging	DIN SPEC 70121, ISO 15118-20 CCS1, CCS2, (NACS)
Charging mode	unidirectional, bidirectional (V2X)

### Technical data

EMC	ECE r10 rev.6
Protection class	IP6K9K
Safety functions	over-temperature, over-current protection, over-voltage, galvanic isolation

### Mechanical data

Dimensions (L x W x H)	460 x 460 x 93 mm
Weight	~ 19 kg
Operating temperature	-40 - +65 °C
Interfaces*	1x CAN J1939 / 1x Service CAN

\* Parameters can be customised to the customer application.

Ready to experience the future of EV charging?

Contact the innoelectric sales team today to learn more about the CEC on-board charger.

Want to test the CEC in your application?

Contact us at [sales@innoelectric.ag](mailto:sales@innoelectric.ag) and order your pre-series sample!

**Pre-Series available now!**

Information is subject to be changed.

**innoelectric AG**

+49 234 60 14 36 70 · [sales@innoelectric.ag](mailto:sales@innoelectric.ag)

© innoelectric AG 2025 · CEC-202501