

# IRHY57034CM (JANSR2N7483T3)

PD-93825F

## Radiation Hardened Power MOSFET Thru-Hole (TO-257AA) 60V, 18A, N-channel, R5 Technology

### Features

- Single event effect (SEE) hardened
- Low  $R_{DS(on)}$
- Low total gate charge
- Simple drive requirements
- Hermetically sealed
- Electrically isolated
- Ceramic eyelets
- ESD rating: Class 1C per MIL-STD-750, Method 1020

### Potential Applications

- DC-DC converter
- Motor drives

### Product Validation

Qualified to JANS screening flow according to MIL-PRF-19500 for space applications

### Description

IR HiRel R5 technology provides high performance power MOSFETs for space applications. This technology has over a decade of proven performance and reliability in satellite applications. These devices have been characterized for both Total Dose and Single Event Effects (SEE). The combination of low  $R_{DS(on)}$  and low gate charge reduces the power losses in switching applications such as DC to DC converters and motor control. These devices retain all of the well-established advantages of MOSFETs such as voltage control, fast switching and temperature stability of electrical parameters.

### Ordering Information

**Table 1** Ordering options

Part number	Package	Screening Level	TID Level
IRHY57034CM	TO-257AA	COTS	100 krad(Si)
JANSR2N7483T3	TO-257AA	JANS	100 krad(Si)
IRHY53034CM	TO-257AA	COTS	300 krad(Si)
JANSF2N7483T3	TO-257AA	JANS	300 krad(Si)
IRHY54034CM	TO-257AA	COTS	500 krad(Si)
JANSG2N7483T3	TO-257AA	JANS	500 krad(Si)

### Product Summary

- $BV_{DSS}$ : 60V
- $I_D$ : 18A
- $R_{DS(on),max}$ : 40m $\Omega$
- $Q_{G,max}$ : 45nC
- REF: MIL-PRF-19500/702

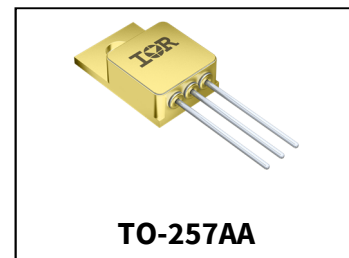

**Table of contents**

**Table of contents**

<b>Features .....</b>	<b>1</b>
<b>Potential Applications.....</b>	<b>1</b>
<b>Product Validation.....</b>	<b>1</b>
<b>Description .....</b>	<b>1</b>
<b>Ordering Information.....</b>	<b>1</b>
<b>Table of contents.....</b>	<b>2</b>
<b>1 Absolute Maximum Ratings .....</b>	<b>3</b>
<b>2 Device Characteristics .....</b>	<b>4</b>
2.1 Electrical Characteristics (Pre-Irradiation).....	4
2.2 Source-Drain Diode Ratings and Characteristics (Pre-Irradiation) .....	5
2.3 Thermal Characteristics .....	5
2.4 Radiation Characteristics.....	5
2.4.1 Electrical Characteristics – Post Total Dose Irradiation .....	5
2.4.2 Single Event Effects – Safe Operating Area.....	6
<b>3 Electrical Characteristics Curves (Pre-irradiation) .....</b>	<b>7</b>
<b>4 Test Circuits (Pre-irradiation) .....</b>	<b>10</b>
<b>5 Package Outline.....</b>	<b>11</b>
<b>Revision history.....</b>	<b>12</b>

## Absolute Maximum Ratings

## 1 Absolute Maximum Ratings

Table 2 Absolute Maximum Ratings (Pre-Irradiation)

Symbol	Parameter	Value	Unit
$I_{D1}$ @ $V_{GS} = 12V$ , $T_C = 25^\circ C$	Continuous Drain Current	18*	A
$I_{D2}$ @ $V_{GS} = 12V$ , $T_C = 100^\circ C$	Continuous Drain Current	18*	A
$I_{DM}$ @ $T_C = 25^\circ C$	Pulsed Drain Current <sup>1</sup>	72	A
$P_D$ @ $T_C = 25^\circ C$	Maximum Power Dissipation	75	W
	Linear Derating Factor	0.6	W/ $^\circ C$
$V_{GS}$	Gate-to-Source Voltage	$\pm 20$	V
$E_{AS}$	Single Pulse Avalanche Energy <sup>2</sup>	110	mJ
$I_{AR}$	Avalanche Current <sup>1</sup>	18	A
$E_{AR}$	Repetitive Avalanche Energy <sup>1</sup>	7.5	mJ
dv/dt	Peak Diode Reverse Recovery <sup>3</sup>	10	V/ns
$T_J$ $T_{STG}$	Operating Junction and Storage Temperature Range	-55 to +150	$^\circ C$
	Lead Temperature	300 (0.063 in. /1.6 mm from case for 10s)	
	Weight	4.3 (Typical)	

\*Current is limited by package

<sup>1</sup> Repetitive Rating; Pulse width limited by maximum junction temperature.<sup>2</sup>  $V_{DD} = 25V$ , starting  $T_J = 25^\circ C$ ,  $L = 0.7mH$ , Peak  $I_L = 18A$ ,  $V_{GS} = 12V$ <sup>3</sup>  $I_{SD} \leq 18A$ ,  $di/dt \leq 234A/\mu s$ ,  $V_{DD} \leq 60V$ ,  $T_J \leq 150^\circ C$

## Device Characteristics

## 2 Device Characteristics

## 2.1 Electrical Characteristics (Pre-Irradiation)

Table 3 Static and Dynamic Electrical Characteristics @  $T_j = 25^\circ\text{C}$  (Unless Otherwise Specified)

Symbol	Parameter	Min.	Typ.	Max.	Unit	Test Conditions
$BV_{DSS}$	Drain-to-Source Breakdown Voltage	60	—	—	V	$V_{GS} = 0V, I_D = 1.0mA$
$\Delta BV_{DSS}/\Delta T_J$	Breakdown Voltage Temp. Coefficient	—	0.057	—	V/ $^\circ\text{C}$	Reference to $25^\circ\text{C}, I_D = 1.0mA$
$R_{DS(on)}$	Static Drain-to-Source On-State Resistance	—	—	40	m $\Omega$	$V_{GS} = 12V, I_{D2} = 18A^1$
$V_{GS(th)}$	Gate Threshold Voltage	2.0	—	4.0	V	$V_{DS} = V_{GS}, I_D = 1mA$
Gfs	Forward Transconductance	16	—	—	S	$V_{DS} = 15V, I_{D2} = 18A^1$
$I_{DSS}$	Zero Gate Voltage Drain Current	—	—	10	$\mu\text{A}$	$V_{DS} = 48V, V_{GS} = 0V$
		—	—	25		$V_{DS} = 48V, V_{GS} = 0V, T_J = 125^\circ\text{C}$
$I_{GSS}$	Gate-to-Source Leakage Forward	—	—	100	nA	$V_{GS} = 20V$
	Gate-to-Source Leakage Reverse	—	—	-100		$V_{GS} = -20V$
$Q_G$	Total Gate Charge	—	—	45	nC	$I_{D1} = 18A$ $V_{DS} = 30V$ $V_{GS} = 12V$
$Q_{GS}$	Gate-to-Source Charge	—	—	10		
$Q_{GD}$	Gate-to-Drain ('Miller') Charge	—	—	15		
$t_{d(on)}$	Turn-On Delay Time	—	—	25	ns	$I_{D1} = 18A^{**}$ $V_{DD} = 30V$ $R_G = 7.5\Omega$ $V_{GS} = 12V$
$t_r$	Rise Time	—	—	100		
$t_{d(off)}$	Turn-Off Delay Time	—	—	35		
$t_f$	Fall Time	—	—	30		
$L_s + L_D$	Total Inductance	—	6.8	—	nH	Measured from Drain lead (6mm / 0.25 in from package) to Source lead (6mm/ 0.25 in from package) with Source wire internally bonded from Source pin to Drain pad
$C_{iss}$	Input Capacitance	—	1152	—	pF	$V_{GS} = 0V$ $V_{DS} = 25V$ $f = 1.0MHz$
$C_{oss}$	Output Capacitance	—	535	—		
$C_{rss}$	Reverse Transfer Capacitance	—	42	—		

\*\* Switching speed maximum limits are based on manufacturing test equipment and capability.

<sup>1</sup> Pulse width  $\leq 300 \mu\text{s}$ ; Duty Cycle  $\leq 2\%$

## Device Characteristics

## 2.2 Source-Drain Diode Ratings and Characteristics (Pre-Irradiation)

Table 4 Source-Drain Diode Characteristics

Symbol	Parameter	Min.	Typ.	Max.	Unit	Test Conditions
$I_S$	Continuous Source Current (Body Diode)	—	—	18	A	
$I_{SM}$	Pulsed Source Current (Body Diode) <sup>1</sup>	—	—	72	A	
$V_{SD}$	Diode Forward Voltage	—	—	1.2	V	$T_J = 25^\circ\text{C}$ , $I_S = 18\text{A}$ , $V_{GS} = 0\text{V}$ <sup>2</sup>
$t_{rr}$	Reverse Recovery Time	—	—	99	ns	$T_J = 25^\circ\text{C}$ , $I_F = 18\text{A}$ , $V_{DD} \leq 25\text{V}$ $di/dt = 100\text{A}/\mu\text{s}$ <sup>2</sup>
$Q_{rr}$	Reverse Recovery Charge	—	—	322	nC	
$t_{on}$	Forward Turn-On Time	Intrinsic turn-on time is negligible (turn-on is dominated by $L_S + L_D$ )				

## 2.3 Thermal Characteristics

Table 5 Thermal Resistance

Symbol	Parameter	Min.	Typ.	Max.	Unit
$R_{\theta JC}$	Junction-to-Case	—	—	1.67	$^\circ\text{C}/\text{W}$
$R_{\theta JA}$	Junction-to- Ambient (Typical socket mount)	—	—	80	

## 2.4 Radiation Characteristics

IR HiRel radiation hardened MOSFETs are tested to verify their radiation hardness capability. The hardness assurance program at IR HiRel is comprised of two radiation environments. Every manufacturing lot is tested for total ionizing dose (per notes 3 and 4) using the TO-3 package. Both pre- and post-irradiation performance are tested and specified using the same drive circuitry and test conditions in order to provide a direct comparison.

## 2.4.1 Electrical Characteristics — Post Total Dose Irradiation

Table 6 Electrical Characteristics @  $T_J = 25^\circ\text{C}$ , Post Total Dose Irradiation<sup>3, 4</sup>

Symbol	Parameter	Up to 500 krad (Si) <sup>5</sup>		Unit	Test Conditions
		Min.	Max.		
$BV_{DSS}$	Drain-to-Source Breakdown Voltage	60	—	V	$V_{GS} = 0\text{V}$ , $I_D = 1.0\text{mA}$
$V_{GS(th)}$	Gate Threshold Voltage	2.0	4.0	V	$V_{DS} = V_{GS}$ , $I_D = 1.0\text{mA}$
$I_{GSS}$	Gate-to-Source Leakage Forward	—	100	nA	$V_{GS} = 20\text{V}$
	Gate-to-Source Leakage Reverse	—	-100		$V_{GS} = -20\text{V}$
$I_{DSS}$	Zero Gate Voltage Drain Current	—	10	$\mu\text{A}$	$V_{DS} = 48\text{V}$ , $V_{GS} = 0\text{V}$
$R_{DS(on)}$	Static Drain-to-Source On-State Resistance (TO-3) <sup>2</sup>	—	34	$\text{m}\Omega$	$V_{GS} = 12\text{V}$ , $I_{D2} = 18\text{A}$
$R_{DS(on)}$	Static Drain-to-Source On-State Resistance (TO-257AA) <sup>2</sup>	—	40	$\text{m}\Omega$	$V_{GS} = 12\text{V}$ , $I_{D2} = 18\text{A}$
$V_{SD}$	Diode Forward Voltage	—	1.2	V	$V_{GS} = 0\text{V}$ , $I_F = 18\text{A}$

<sup>1</sup> Repetitive Rating; Pulse width limited by maximum junction temperature.

<sup>2</sup> Pulse width  $\leq 300 \mu\text{s}$ ; Duty Cycle  $\leq 2\%$

<sup>3</sup> Total Dose Irradiation with  $V_{GS}$  Bias.  $V_{GS} = 12\text{V}$  applied and  $V_{DS} = 0$  during irradiation per MIL-STD-750, Method 1019, condition A.

<sup>4</sup> Total Dose Irradiation with  $V_{DS}$  Bias.  $V_{DS} = 48\text{V}$  applied and  $V_{GS} = 0$  during irradiation per MIL-STD-750, Method 1019, condition A.

<sup>5</sup> Part numbers IRHY57034CM (JANSR2N7483T3), IRHY53034CM (JANSF2N7483T3) and IRHY54034CM (JANSF2N7483T3)

Device Characteristics

2.4.2 Single Event Effects — Safe Operating Area

IR HiRel radiation hardened MOSFETs have been characterized in heavy ion environment for Single Event Effects (SEE). Single Event Effects characterization is illustrated in Fig. 1 and Table 7.

Table 7 Typical Single Event Effects Safe Operating Area

LET (MeV·cm <sup>2</sup> /mg)	Energy (MeV)	Range (μm)	V <sub>DS</sub> (V)				
			V <sub>GS</sub> = 0V	V <sub>GS</sub> = -5V	V <sub>GS</sub> = -10V	V <sub>GS</sub> = -15V	V <sub>GS</sub> = -20V
38 ± 5%	300 ± 7.5%	38 ± 7.5%	60	60	60	50	30
61 ± 5%	330 ± 7.5%	31 ± 10%	46	46	35	25	15
84 ± 5%	350 ± 10%	28 ± 7.5%	35	30	25	20	14

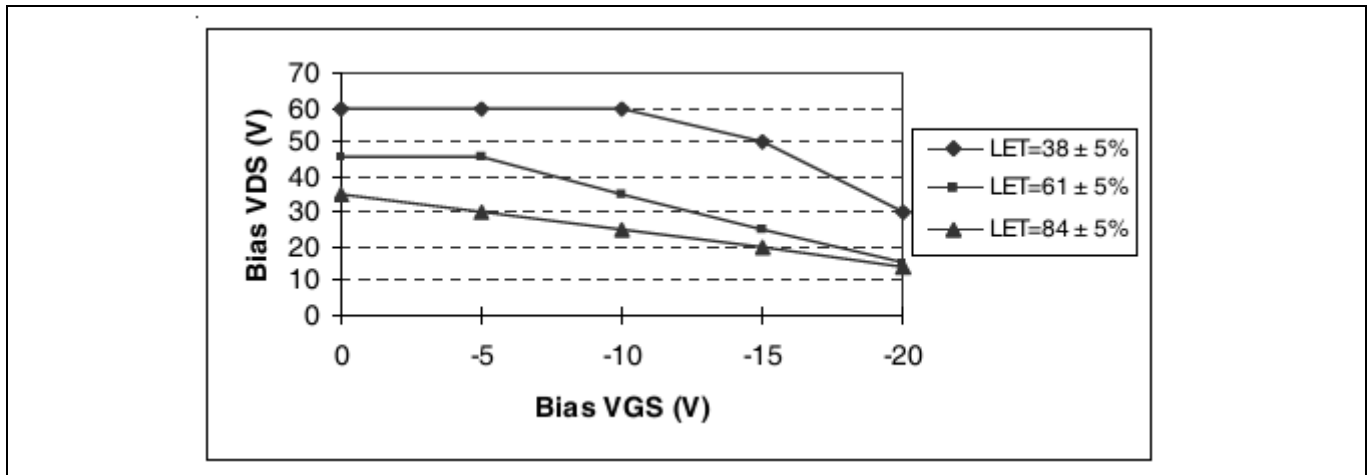

Figure 1 Typical Single Event Effect, Safe Operating Area

Electrical Characteristics Curves (Pre-irradiation)

### 3 Electrical Characteristics Curves (Pre-irradiation)

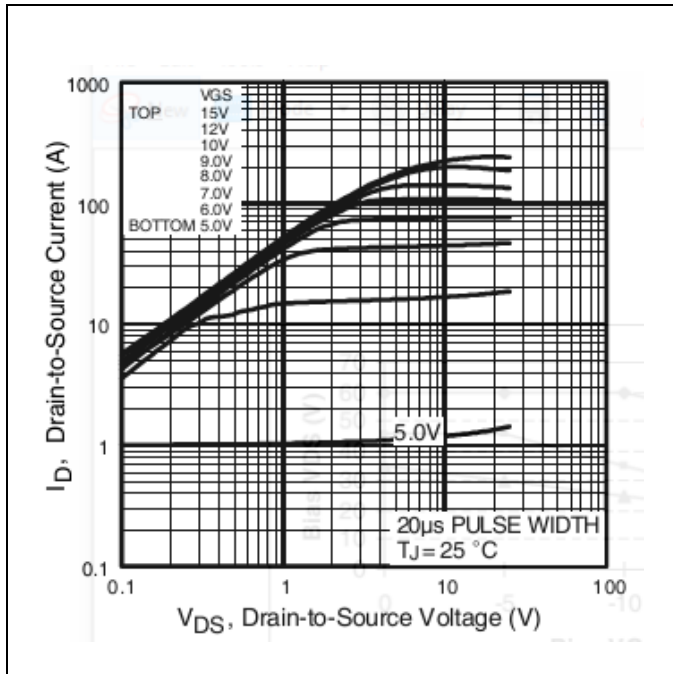

Figure 2 Typical Output Characteristics

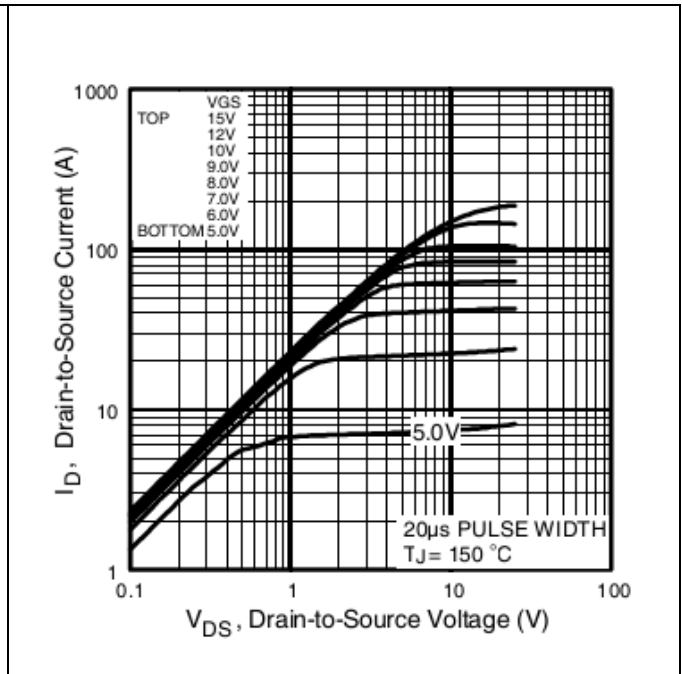

Figure 3 Typical Output Characteristics

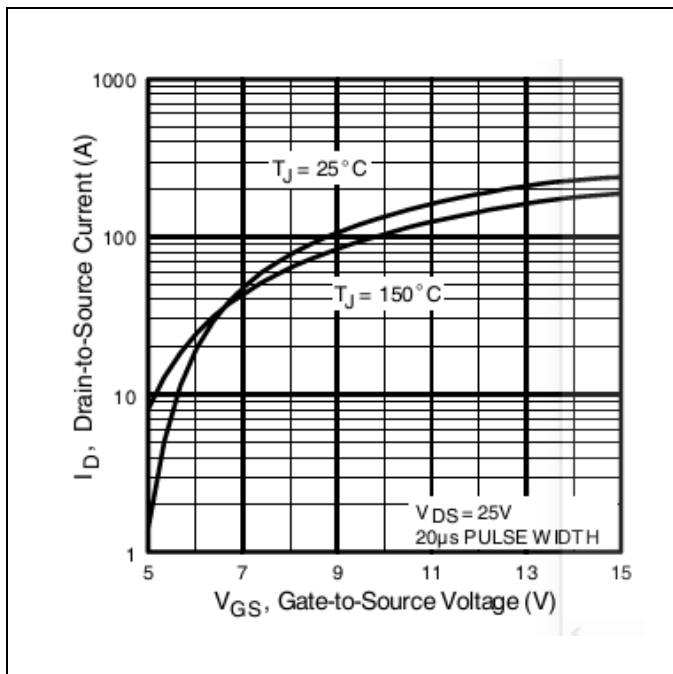

Figure 4 Typical Transfer Characteristics

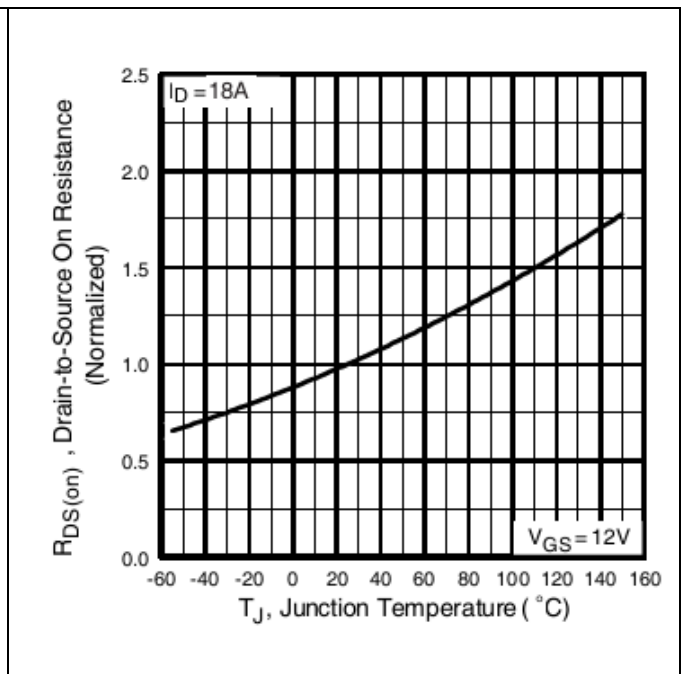
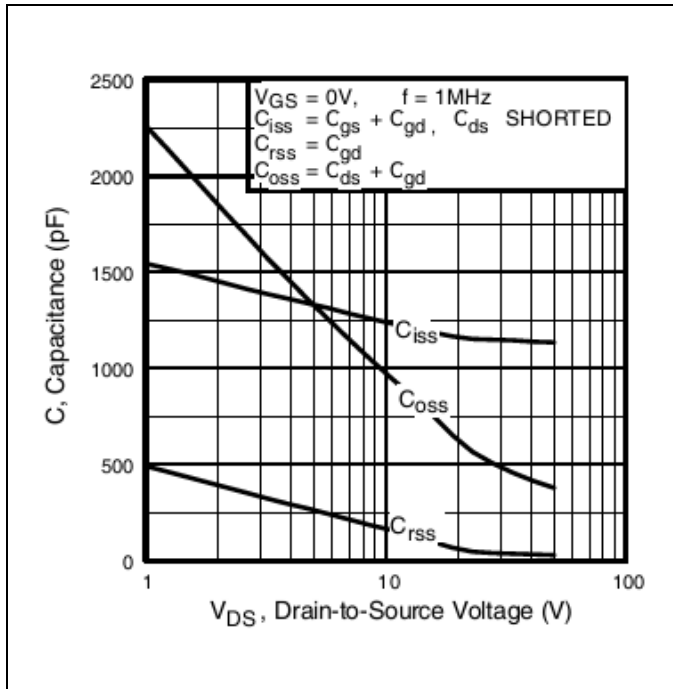

Figure 5 Normalized On-Resistance Vs. Temperature

**IRHY57034CM (JANSR2N7483T3)**

**Radiation Hardened Power MOSFET Thru-Hole (TO-257AA)**

**Electrical Characteristics Curves (Pre-irradiation)**



**Figure 6 Typical Capacitance Vs. Drain-to-Source Voltage**

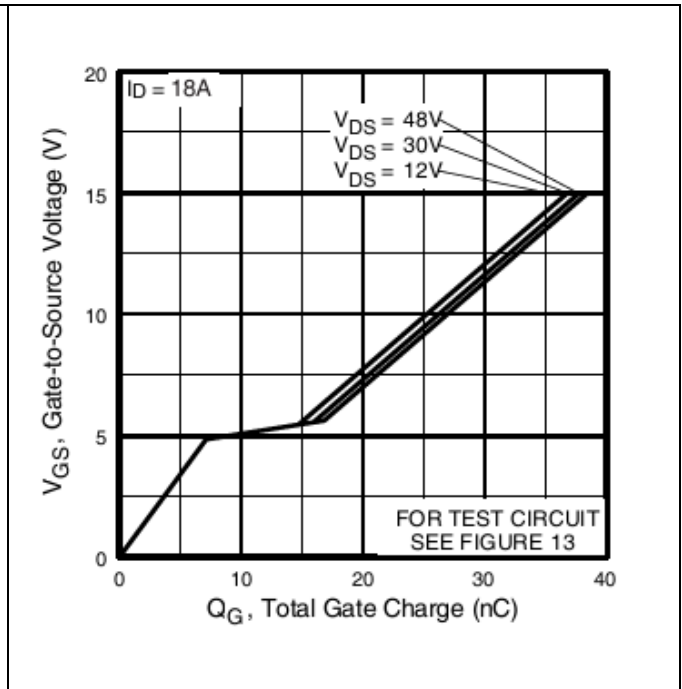

**Figure 7 Typical Gate-to-Source Voltage Vs. Typical Gate Charge**

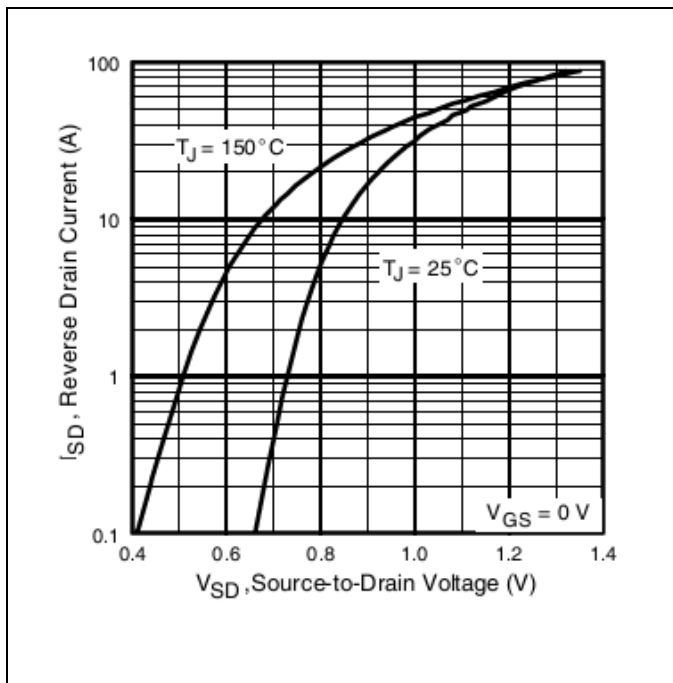

**Figure 8 Typical Source-Drain Current Vs. Diode Forward Voltage**

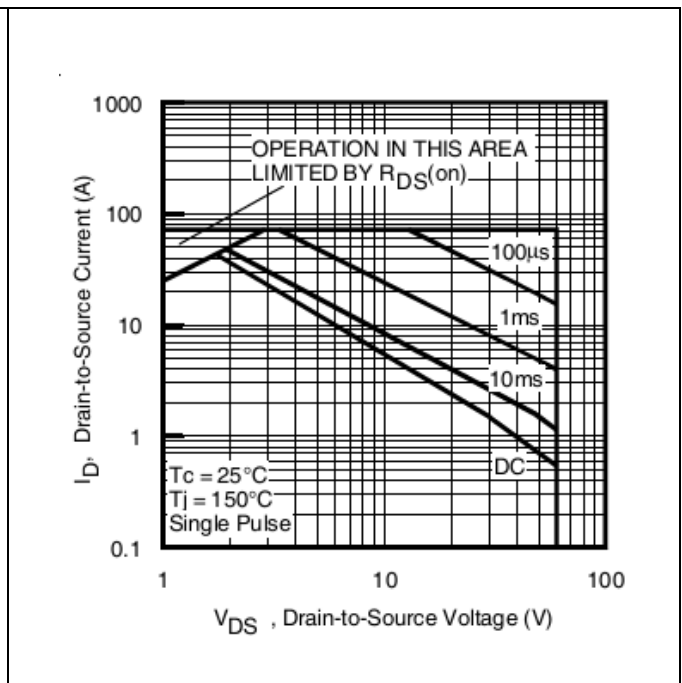

**Figure 9 Maximum Safe Operating Area**



**IRHY57034CM (JANSR2N7483T3)**

**Radiation Hardened Power MOSFET Thru-Hole (TO-257AA)**

**Electrical Characteristics Curves (Pre-irradiation)**

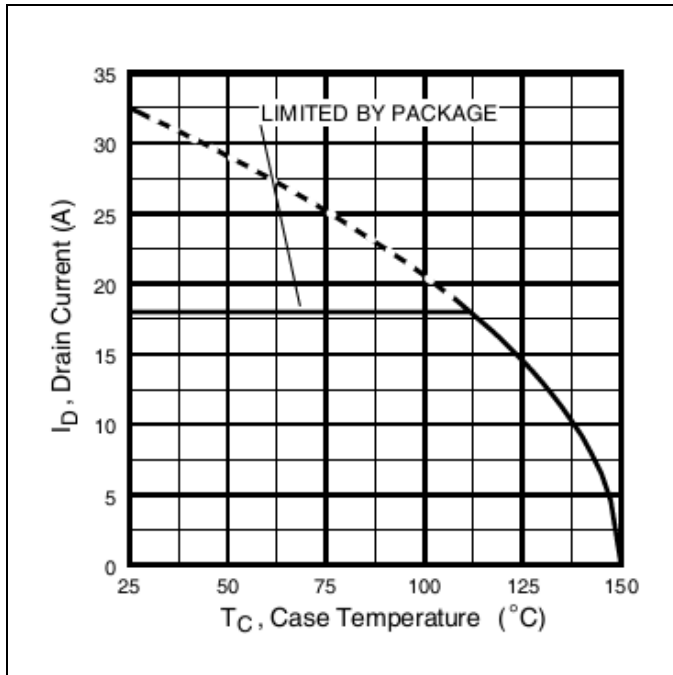

**Figure 10 Maximum Drain Current Vs. Case Temperature**

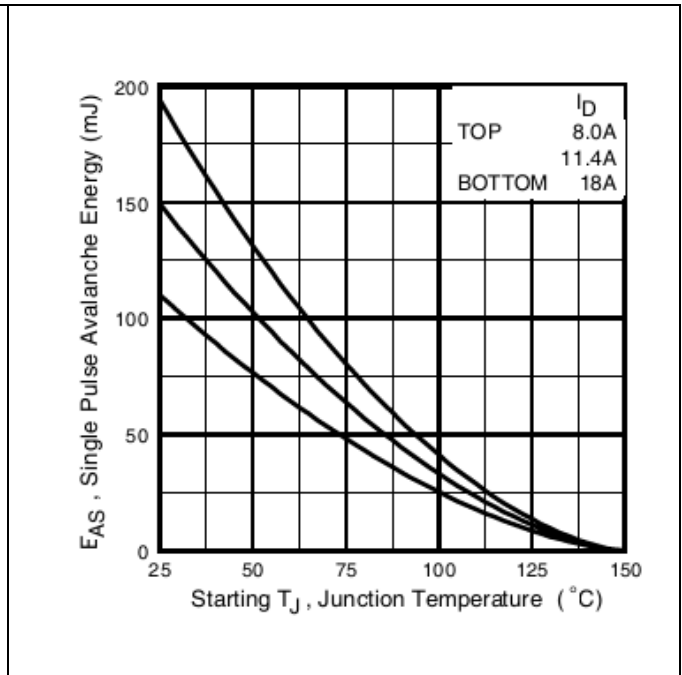

**Figure 11 Maximum Avalanche Energy Vs. Junction Temperature**

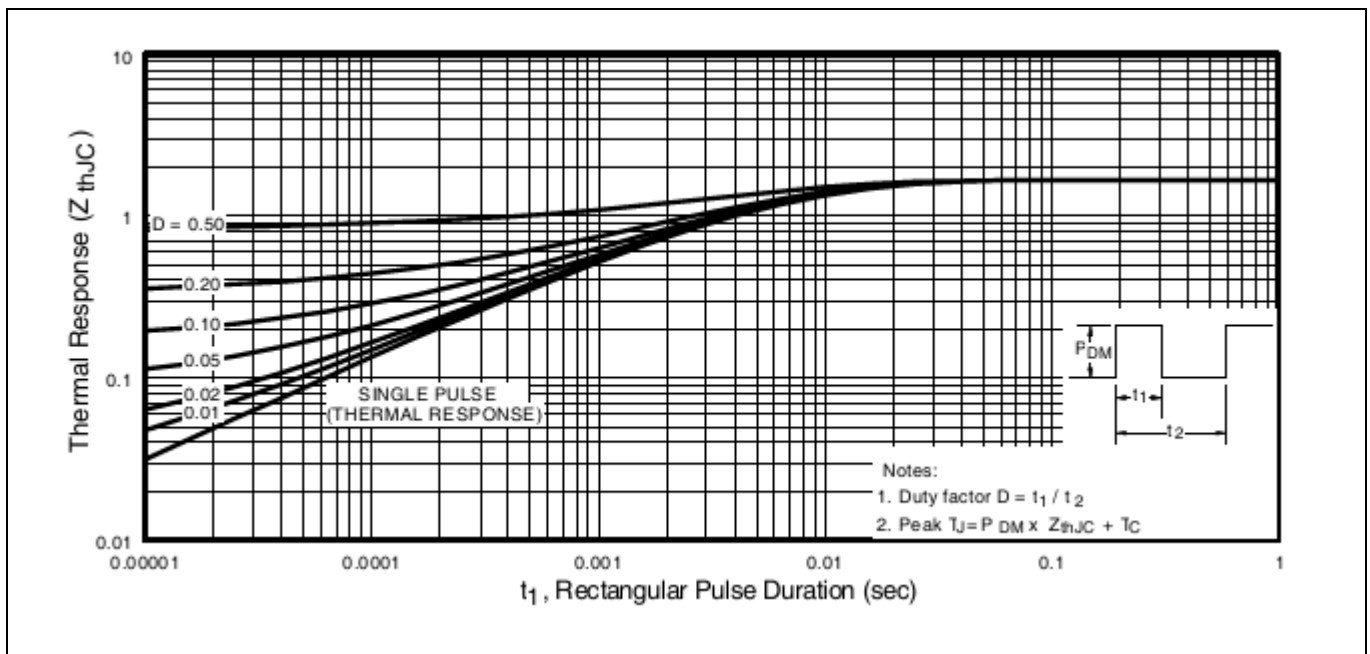

**Figure 12 Maximum Effective Transient Thermal Impedance, Junction-to-Case**

# IRHY57034CM (JANSR2N7483T3)

## Radiation Hardened Power MOSFET Thru-Hole (TO-257AA)

### Test Circuits (Pre-irradiation)

#### 4 Test Circuits (Pre-irradiation)

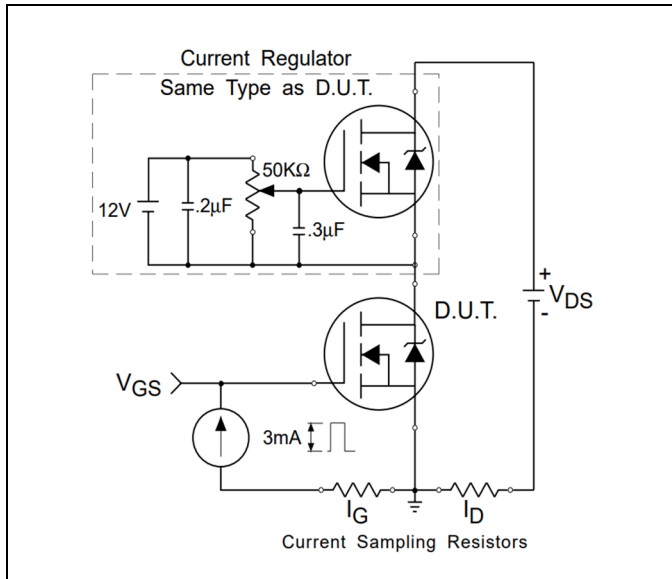

Figure 13 Gate Charge Test Circuit

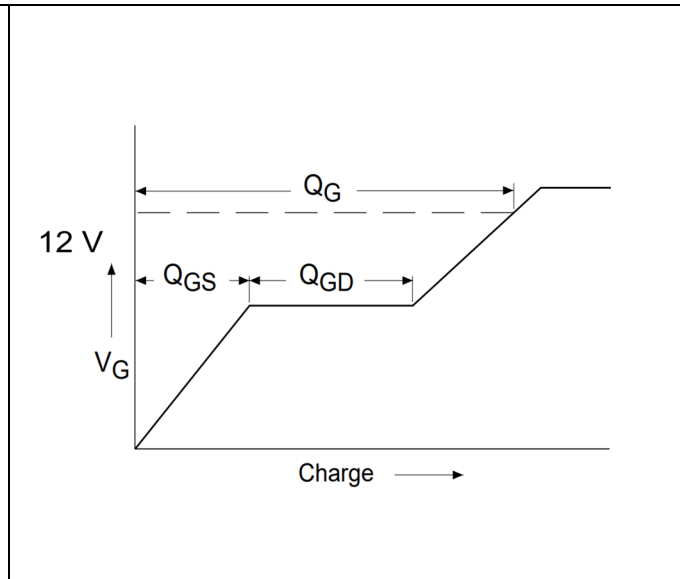

Figure 14 Gate Charge Waveform

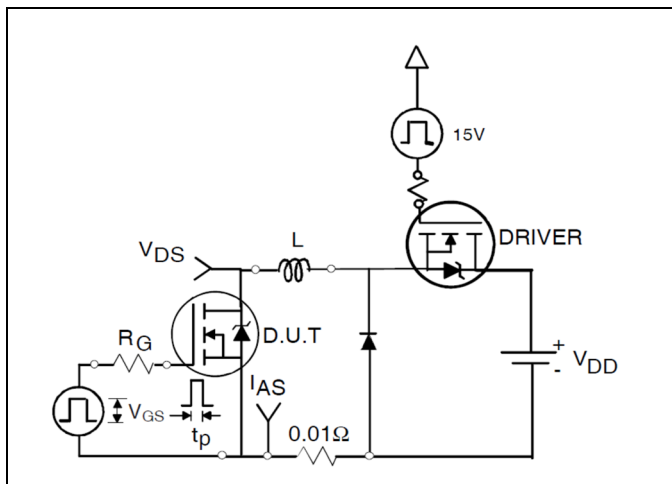

Figure 15 Unclamped Inductive Test Circuit

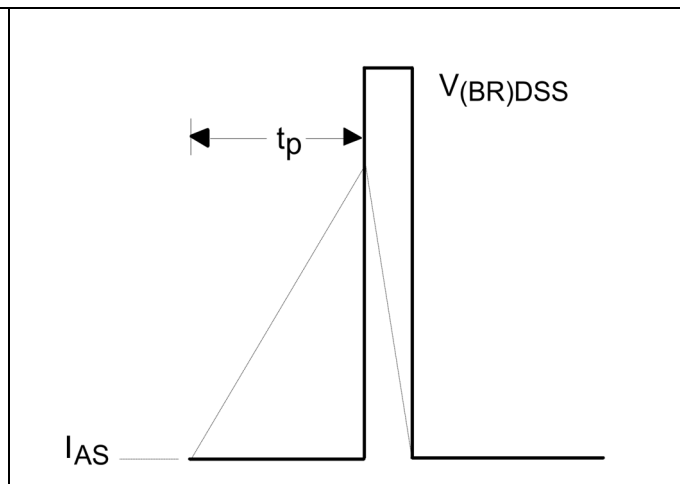

Figure 16 Unclamped Inductive Waveform

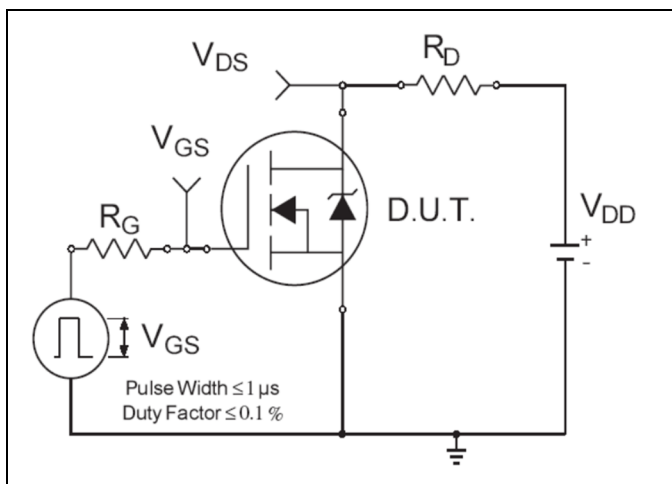

Figure 17 Switching Time Test Circuit

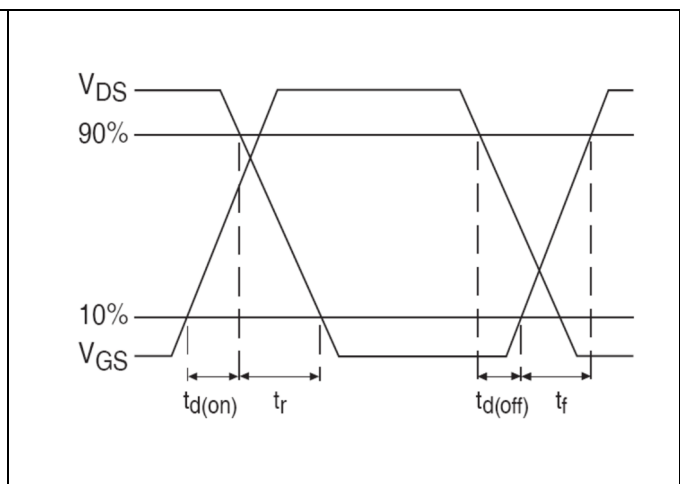

Figure 18 Switching Time Waveforms

# IRHY57034CM (JANSR2N7483T3)

## Radiation Hardened Power MOSFET Thru-Hole (TO-257AA)

### Package Outline

## 5 Package Outline

Note: For the most updated package outline, please see the website: [TO-257AA](http://www.infineon.com/toc-257aa)

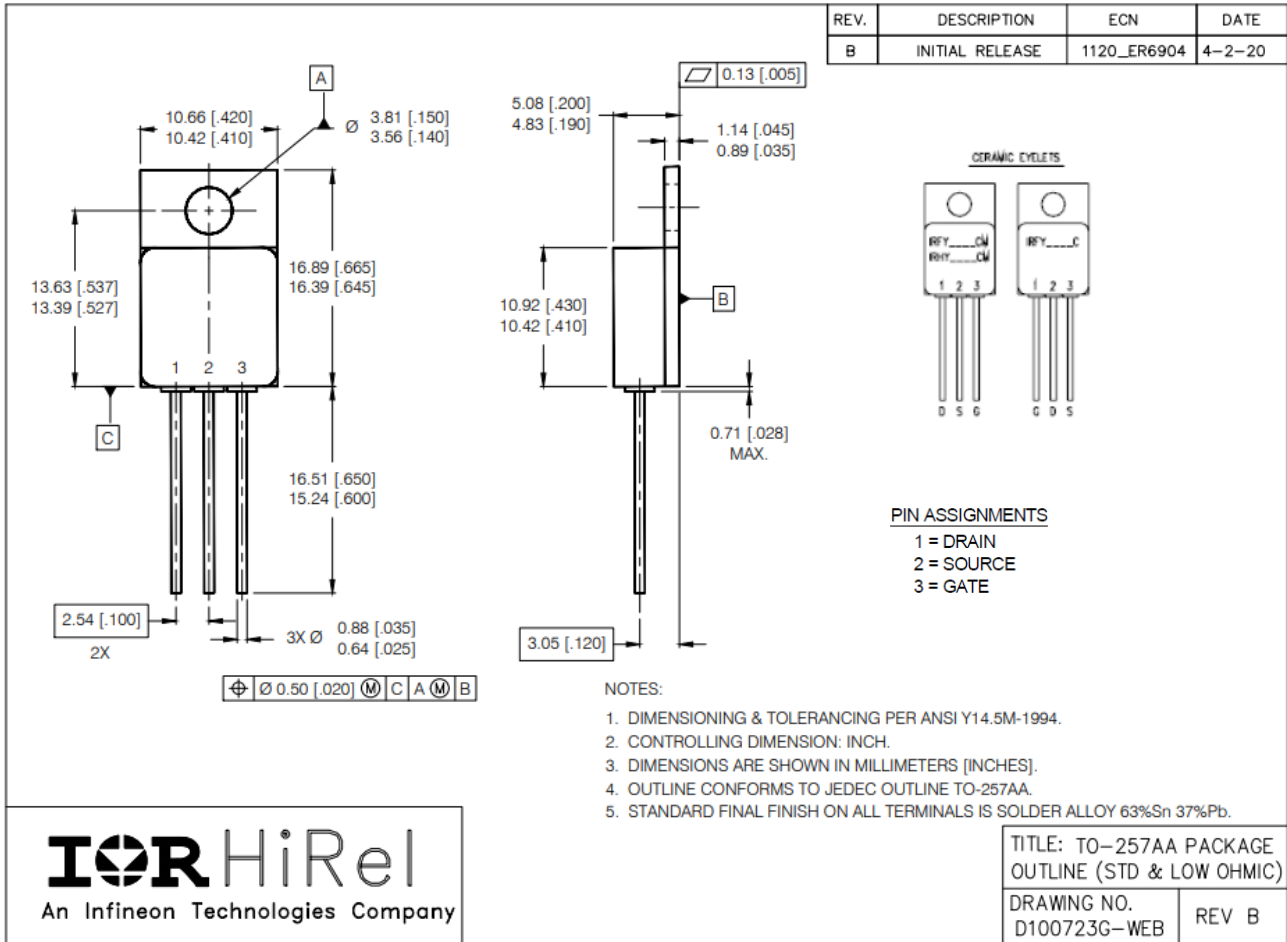

### BERYLLIA WARNING PER MIL-PRF-19500

Package containing beryllia shall not be ground, sandblasted, machined, or have other operations performed on them which will produce beryllia or beryllium dust. Furthermore, beryllium oxide packages shall not be placed in acids that will produce fumes containing beryllium.

# IRHY57034CM (JANSR2N7483T3)

## Radiation Hardened Power MOSFET Thru-Hole (TO-257AA)

### Revision history

### Revision history

Document version	Date of release	Description of changes
	01/26/2000	Datasheet (PD-93825)
Rev A	04/17/2001	Updated switch time test condition
Rev B	07/18/2002	Updated IDSS max for 1000KRad(si)
Rev C	05/06/2004	Added QPL part number
Rev D	04/24/2006	Updated 600kRad(si) to 500kRad(si)
Rev E	10/19/2011	Updated SEE table
Rev F	05/26/2022	Updated based on ECN-1120_09018

## Trademarks

All referenced product or service names and trademarks are the property of their respective owners.

**Edition 2022-05-26**

### Published by

**International Rectifier HiRel Products,  
Inc.**

**An Infineon Technologies company  
El Segundo, California 90245 USA**

**© 2022 Infineon Technologies AG.  
All Rights Reserved.**

**Do you have a question about this  
document?**

**Email: [erratum@infineon.com](mailto:erratum@infineon.com)**

**Document reference**

## IMPORTANT NOTICE

The information given in this document shall in no event be regarded as a guarantee of conditions or characteristics ("Beschaffheitsgarantie").

With respect to any examples, hints or any typical values stated herein and/or any information regarding the application of the product, Infineon Technologies hereby disclaims any and all warranties and liabilities of any kind, including without limitation warranties of non-infringement of intellectual property rights of any third party.

In addition, any information given in this document is subject to customer's compliance with its obligations stated in this document and any applicable legal requirements, norms and standards concerning customer's products and any use of the product of Infineon Technologies in customer's applications.

The data contained in this document is exclusively intended for technically trained staff. It is the responsibility of customer's technical departments to evaluate the suitability of the product for the intended application and the completeness of the product information given in this document with respect to such application.

For further information on the product, technology, delivery terms and conditions and prices please contact your nearest Infineon Technologies office ([www.infineon.com](http://www.infineon.com)).

## WARNINGS

Due to technical requirements components may contain dangerous substances. For information on the types in question please contact your nearest International Rectifier HiRel Products, Inc., an Infineon Technologies company, office.

International Rectifier HiRel Components may only be used in life-support devices or systems with the expressed written approval of International Rectifier HiRel Products, Inc., an Infineon Technologies company, if failure of such components can reasonably be expected to cause the failure of that life-support device or system, or to affect the safety and effectiveness of that device or system.

Infineon Technologies' products may not be used in any applications where a failure of the product or any consequences of the use thereof can reasonably be expected to result in personal injury.

Life support devices or systems are intended to be implanted in the human body, or to support and/or maintain and sustain and/or protect human life. If they fail, it is reasonable to assume that the health of the user or other persons may be endangered.