

IRHN7230

PD-90822D

Radiation Hardened Power MOSFET Surface-Mount (SMD-1) 200V, 9.0A, N-channel, Rad Hard HEXFET™ Technology

Features

- Single event effect (SEE) hardened
- Low $R_{DS(on)}$
- Low total gate charge
- Proton tolerant
- Simple drive requirements
- Hermetically sealed
- Ceramic package
- Light weight
- ESD rating: Class 1C per MIL-STD-750, Method 1020

Potential Applications

- DC-DC converter
- Motor drives

Product Validation

Qualified according to MIL-PRF-19500 for space applications

Description

IR HiRel rad hard HEXFET technology provides high performance power MOSFETs for space applications. This technology has over a decade of proven performance and reliability in satellite applications. These devices have been characterized for both Total Dose and Single Event Effects (SEE). The combination of low $R_{DS(on)}$ and low gate charge reduces the power losses in switching applications such as DC to DC converters and motor control. These devices retain all of the well-established advantages of MOSFETs such as voltage control, fast switching and temperature stability of electrical parameters.

Ordering Information

Table 1 **Ordering options**

Part number	Package	Screening Level	TID Level
IRHN7230	SMD-1	COTS	100 krad(Si)
IRHN3230	SMD-1	COTS	300 krad(Si)
IRHN4230	SMD-1	COTS	500 krad(Si)

Product Summary

- BV_{DSS} : 200V
- I_D : 9.0A
- $R_{DS(on),max}$: 0.40 Ω
- $Q_{G,max}$: 50nC

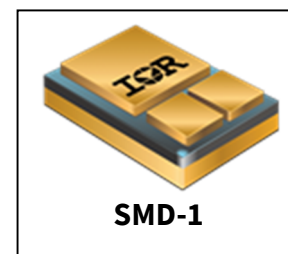

Table of contents

Table of contents

Features 1

Potential Applications..... 1

Product Validation..... 1

Description 1

Ordering Information..... 1

Table of contents..... 2

1 Absolute Maximum Ratings 3

2 Device Characteristics 4

2.1 Electrical Characteristics (Pre-Irradiation).....4

2.2 Source-Drain Diode Ratings and Characteristics (Pre-Irradiation)5

2.3 Thermal Characteristics5

2.4 Radiation Characteristics.....5

2.4.1 Electrical Characteristics – Post Total Dose Irradiation5

2.4.2 Single Event Effects – Safe Operating Area6

3 Electrical Characteristics Curves (Pre-irradiation) 7

4 Test Circuits (Pre-irradiation)10

5 Package Outline11

Revision history.....12

Absolute Maximum Ratings

1 Absolute Maximum Ratings

Table 2 Absolute Maximum Ratings (Pre-Irradiation)

Symbol	Parameter	Value	Unit
$I_{D1} @ V_{GS} = 12V, T_C = 25^\circ C$	Continuous Drain Current	9.0	A
$I_{D2} @ V_{GS} = 12V, T_C = 100^\circ C$	Continuous Drain Current	6.0	A
$I_{DM} @ T_C = 25^\circ C$	Pulsed Drain Current ¹	36	A
$P_D @ T_C = 25^\circ C$	Maximum Power Dissipation	75	W
	Linear Derating Factor	0.60	W/°C
V_{GS}	Gate-to-Source Voltage	± 20	V
E_{AS}	Single Pulse Avalanche Energy ²	330	mJ
I_{AR}	Avalanche Current ¹	9.0	A
E_{AR}	Repetitive Avalanche Energy ¹	7.5	mJ
dv/dt	Peak Diode Reverse Recovery ³	5.0	V/ns
T_J T_{STG}	Operating Junction and Storage Temperature Range	-55 to +150	°C
	Lead Temperature	300 (for 5s)	
	Weight	2.6 (Typical)	

¹ Repetitive Rating; Pulse width limited by maximum junction temperature.

² $V_{DD} = 25V$, starting $T_J = 25^\circ C$, $L = 8.15mH$, Peak $I_L = 9.0A$, $V_{GS} = 12V$

³ $I_{SD} \leq 9.0A$, $di/dt \leq 120A/\mu s$, $V_{DD} \leq 200V$, $T_J \leq 150^\circ C$

Device Characteristics

2 Device Characteristics

2.1 Electrical Characteristics (Pre-Irradiation)

Table 3 Static and Dynamic Electrical Characteristics @ $T_j = 25^\circ\text{C}$ (Unless Otherwise Specified)

Symbol	Parameter	Min.	Typ.	Max.	Unit	Test Conditions
BV_{DSS}	Drain-to-Source Breakdown Voltage	200	—	—	V	$V_{GS} = 0V, I_D = 1.0mA$
$\Delta BV_{DSS}/\Delta T_J$	Breakdown Voltage Temp. Coefficient	—	0.27	—	V/ $^\circ\text{C}$	Reference to $25^\circ\text{C}, I_D = 1.0mA$
$R_{DS(on)}$	Static Drain-to-Source On-State Resistance	—	—	0.40	Ω	$V_{GS} = 12V, I_{D2} = 6.0A^1$
		—	—	0.49		$V_{GS} = 12V, I_{D1} = 9.0A^1$
$V_{GS(th)}$	Gate Threshold Voltage	2.0	—	4.0	V	$V_{DS} = V_{GS}, I_D = 1mA$
G_{fs}	Forward Transconductance	3.0	—	—	S	$V_{DS} = 15V, I_{D2} = 6.0A^1$
I_{DSS}	Zero Gate Voltage Drain Current	—	—	25	μA	$V_{DS} = 160V, V_{GS} = 0V$
		—	—	250		$V_{DS} = 160V, V_{GS} = 0V, T_J = 125^\circ\text{C}$
I_{GSS}	Gate-to-Source Leakage Forward	—	—	100	nA	$V_{GS} = 20V$
	Gate-to-Source Leakage Reverse	—	—	-100		$V_{GS} = -20V$
Q_G	Total Gate Charge	—	—	50	nC	$I_{D1} = 9.0A$
Q_{GS}	Gate-to-Source Charge	—	—	10		$V_{DS} = 100V$
Q_{GD}	Gate-to-Drain ('Miller') Charge	—	—	20		$V_{GS} = 12V$
$t_{d(on)}$	Turn-On Delay Time	—	—	35	ns	$I_{D1} = 9.0A^{**}$ $V_{DD} = 100V$ $R_G = 7.5\Omega$ $V_{GS} = 12V$
t_r	Rise Time	—	—	80		
$t_{d(off)}$	Turn-Off Delay Time	—	—	60		
t_f	Fall Time	—	—	46		
$L_s + L_D$	Total Inductance	—	4.0	—	nH	Measured from center of Drain pad to center of Source pad
C_{iss}	Input Capacitance	—	1100	—	pF	$V_{GS} = 0V$ $V_{DS} = 25V$ $f = 1.0MHz$
C_{oss}	Output Capacitance	—	250	—		
C_{rss}	Reverse Transfer Capacitance	—	65	—		

** Switching speed maximum limits are based on manufacturing test equipment and capability.

¹ Pulse width $\leq 300 \mu s$; Duty Cycle $\leq 2\%$

Device Characteristics

2.2 Source-Drain Diode Ratings and Characteristics (Pre-Irradiation)

Table 4 Source-Drain Diode Characteristics

Symbol	Parameter	Min.	Typ.	Max.	Unit	Test Conditions
I_S	Continuous Source Current (Body Diode)	—	—	9.0	A	
I_{SM}	Pulsed Source Current (Body Diode) ¹	—	—	36	A	
V_{SD}	Diode Forward Voltage	—	—	1.6	V	$T_J = 25^\circ\text{C}$, $I_S = 9.0\text{A}$, $V_{GS} = 0\text{V}$ ²
t_{rr}	Reverse Recovery Time	—	—	460	ns	$T_J = 25^\circ\text{C}$, $I_F = 9.0\text{A}$, $V_{DD} \leq 50\text{V}$ $di/dt = 100\text{A}/\mu\text{s}$ ²
Q_{rr}	Reverse Recovery Charge	—	—	5.0	μC	
t_{on}	Forward Turn-On Time	Intrinsic turn-on time is negligible (turn-on is dominated by $L_S + L_D$)				

2.3 Thermal Characteristics

Table 5 Thermal Resistance

Symbol	Parameter	Min.	Typ.	Max.	Unit
$R_{\theta JC}$	Junction-to-Case	—	—	1.67	$^\circ\text{C}/\text{W}$
$R_{\theta PCB}$	Junction-to-PC Board (soldered to 1 inch square cu clad board)	—	7.5	—	

2.4 Radiation Characteristics

IR HiRel radiation hardened MOSFETs are tested to verify their radiation hardness capability. The hardness assurance program at IR HiRel is comprised of two radiation environments. Every manufacturing lot is tested for total ionizing dose (per notes 3 and 4) using the TO-3 package. Both pre- and post-irradiation performance are tested and specified using the same drive circuitry and test conditions in order to provide a direct comparison.

2.4.1 Electrical Characteristics — Post Total Dose Irradiation

Table 6 Electrical Characteristics @ $T_J = 25^\circ\text{C}$, Post Total Dose Irradiation^{3, 4}

Symbol	Parameter	100 krad (Si) ⁵		Up to 500 krad (Si) ⁶		Unit	Test Conditions
		Min.	Max.	Min.	Max.		
BV_{DSS}	Drain-to-Source Breakdown Voltage	200	—	200	—	V	$V_{GS} = 0\text{V}$, $I_D = 1.0\text{mA}$
$V_{GS(th)}$	Gate Threshold Voltage	2.0	4.0	1.25	4.5	V	$V_{DS} = V_{GS}$, $I_D = 1.0\text{mA}$
I_{GSS}	Gate-to-Source Leakage Forward	—	100	—	100	nA	$V_{GS} = 20\text{V}$
	Gate-to-Source Leakage Reverse	—	-100	—	-100		$V_{GS} = -20\text{V}$
I_{DSS}	Zero Gate Voltage Drain Current	—	25	—	25	μA	$V_{DS} = 160\text{V}$, $V_{GS} = 0\text{V}$
$R_{DS(on)}$	Static Drain-to-Source On-State Resistance (TO-3) ²	—	0.40	—	0.53	Ω	$V_{GS} = 12\text{V}$, $I_{D2} = 6.0\text{A}$
$R_{DS(on)}$	Static Drain-to-Source On-State Resistance (SMD-1) ²	—	0.40	—	0.53	Ω	$V_{GS} = 12\text{V}$, $I_{D2} = 6.0\text{A}$
V_{SD}	Diode Forward Voltage	—	1.6	—	1.6	V	$V_{GS} = 0\text{V}$, $I_F = 9.0\text{A}$

¹ Repetitive Rating; Pulse width limited by maximum junction temperature.

² Pulse width $\leq 300\ \mu\text{s}$; Duty Cycle $\leq 2\%$

³ Total Dose Irradiation with V_{GS} Bias. $V_{GS} = 12\text{V}$ applied and $V_{DS} = 0$ during irradiation per MIL-STD-750, Method 1019, condition A.

⁴ Total Dose Irradiation with V_{DS} Bias. $V_{DS} = 160\text{V}$ applied and $V_{GS} = 0$ during irradiation per MIL-STD-750, Method 1019, condition A.

⁵ Part numbers IRHN7230

⁶ Part numbers IRHN3230 and IRHN4230

Radiation Hardened Power MOSFET Surface-Mount (SMD-1)

Device Characteristics

2.4.2 Single Event Effects — Safe Operating Area

IR HiRel radiation hardened MOSFETs have been characterized in heavy ion environment for Single Event Effects (SEE). Single Event Effects characterization is illustrated in Fig. 1 and Table 7.

Table 7 Typical Single Event Effects Safe Operating Area

Ion	LET (MeV·cm ² /mg)	Energy (MeV)	Range (μm)	V _{DS} (V)				
				V _{GS} = 0V	V _{GS} = -5V	V _{GS} = -10V	V _{GS} = -15V	V _{GS} = -20V
Cu	28	285	43	190	180	170	125	—
Br	36.8	305	39	100	100	100	50	—

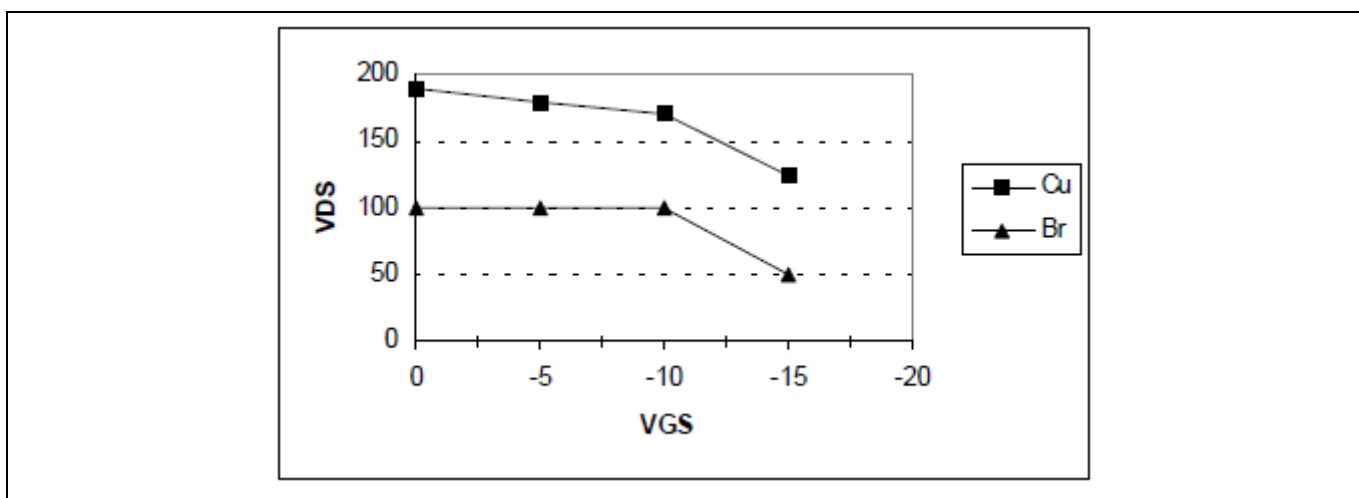

Figure 1 Typical Single Event Effect, Safe Operating Area

3 Electrical Characteristics Curves (Pre-irradiation)

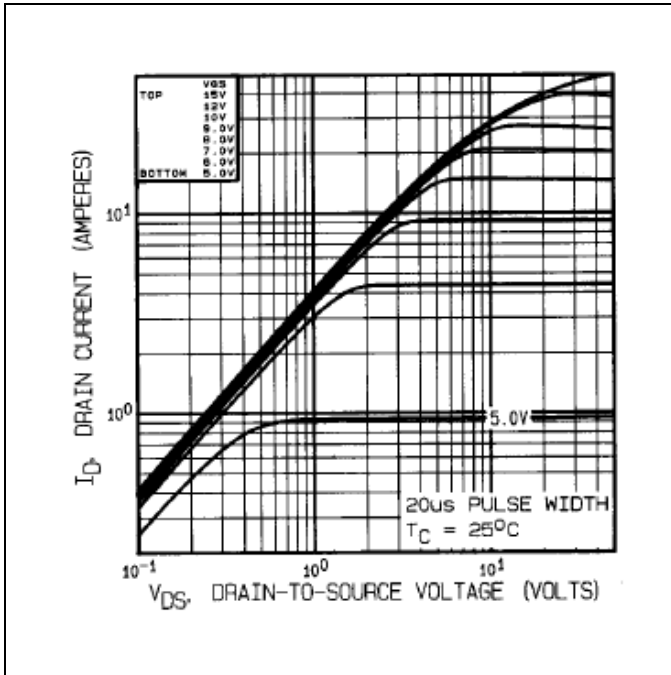

Figure 2 Typical Output Characteristics

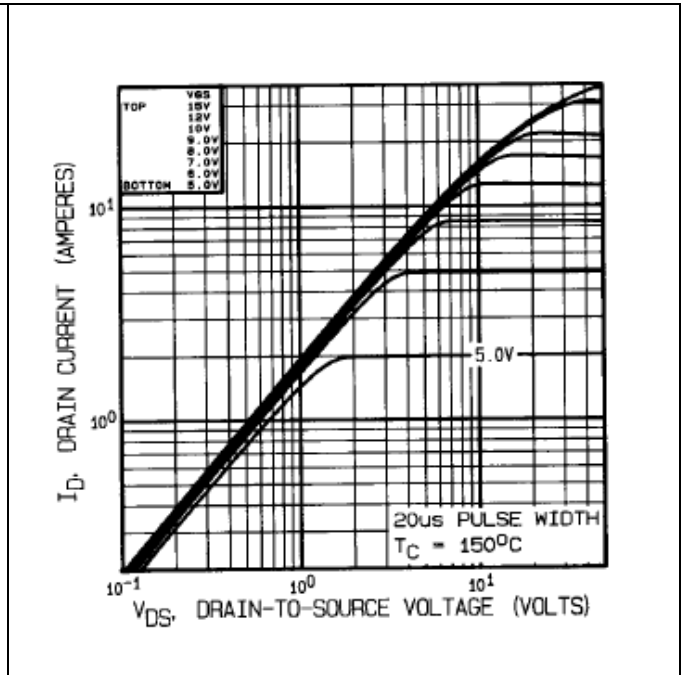

Figure 3 Typical Output Characteristics

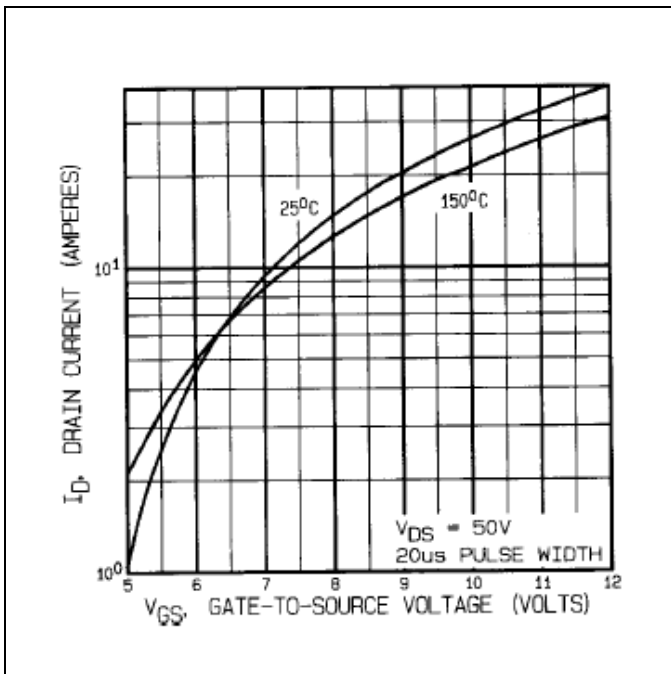

Figure 4 Typical Transfer Characteristics

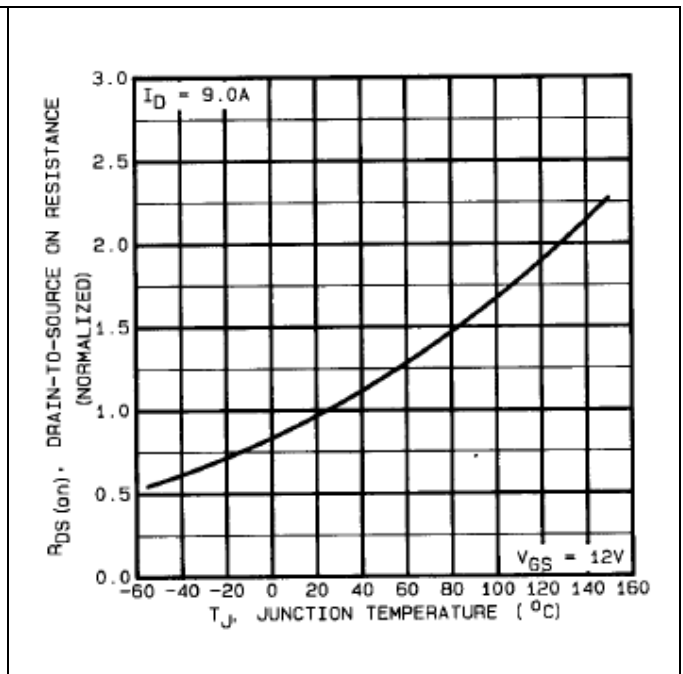

Figure 5 Normalized On-Resistance Vs. Temperature

IRHN7230

Radiation Hardened Power MOSFET Surface-Mount (SMD-1)

Electrical Characteristics Curves (Pre-irradiation)

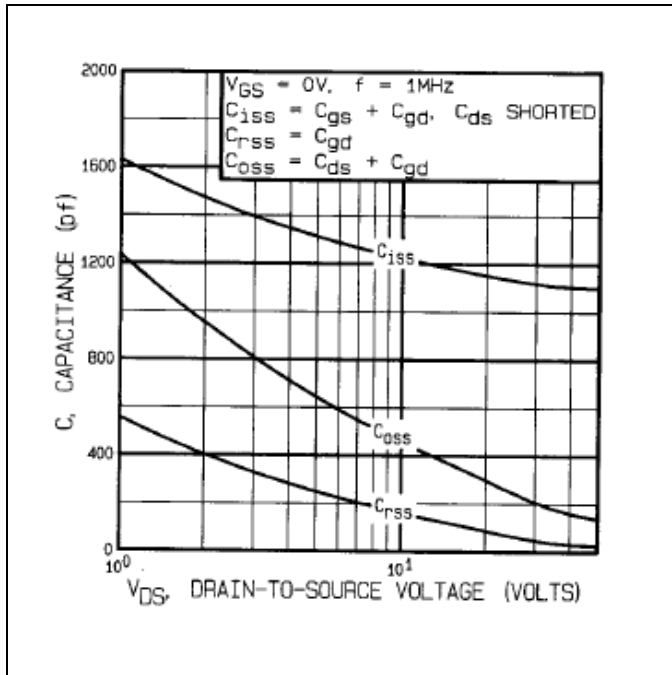

Figure 6 Typical Capacitance Vs. Drain-to-Source Voltage

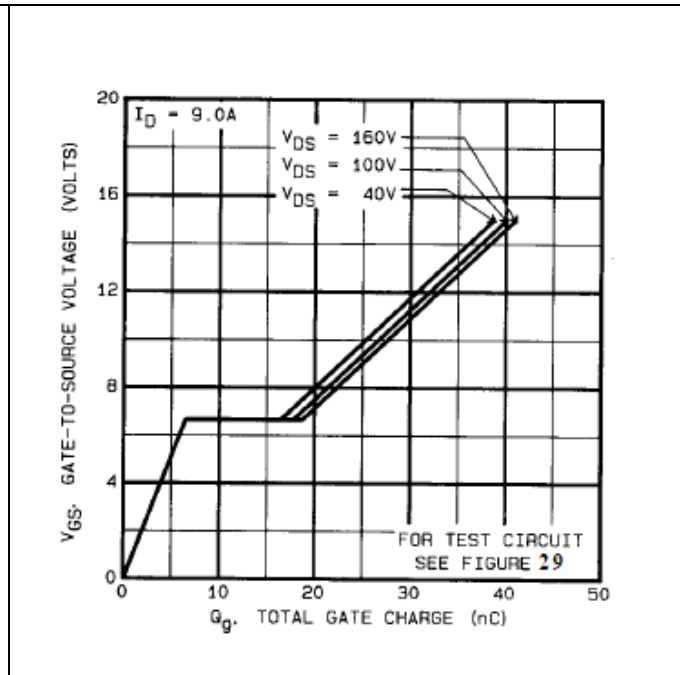

Figure 7 Typical Gate-to-Source Voltage Vs. Typical Gate Charge

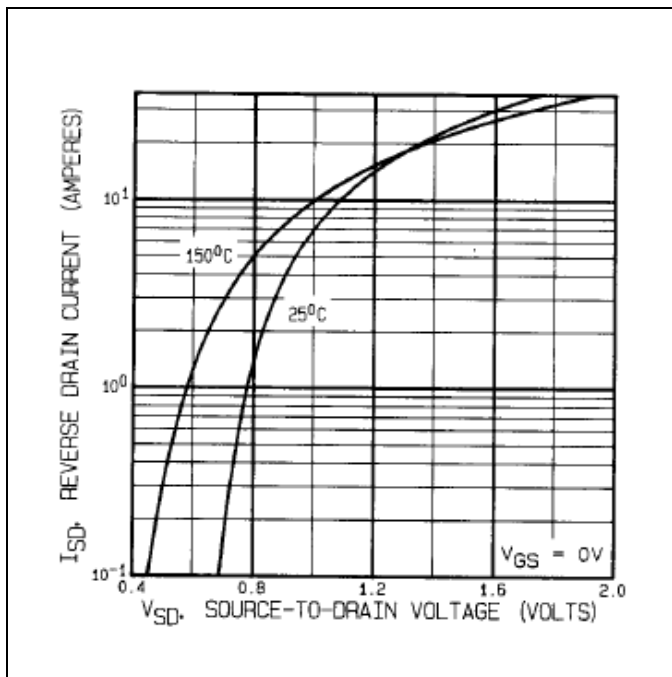

Figure 8 Typical Source-Drain Current Vs. Diode Forward Voltage

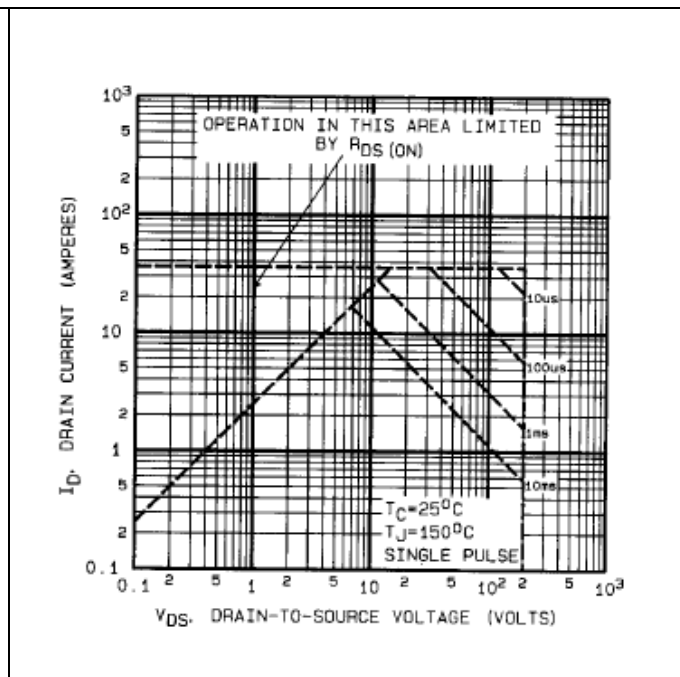

Figure 9 Maximum Safe Operating Area

IRHN7230

Radiation Hardened Power MOSFET Surface-Mount (SMD-1)

Electrical Characteristics Curves (Pre-irradiation)

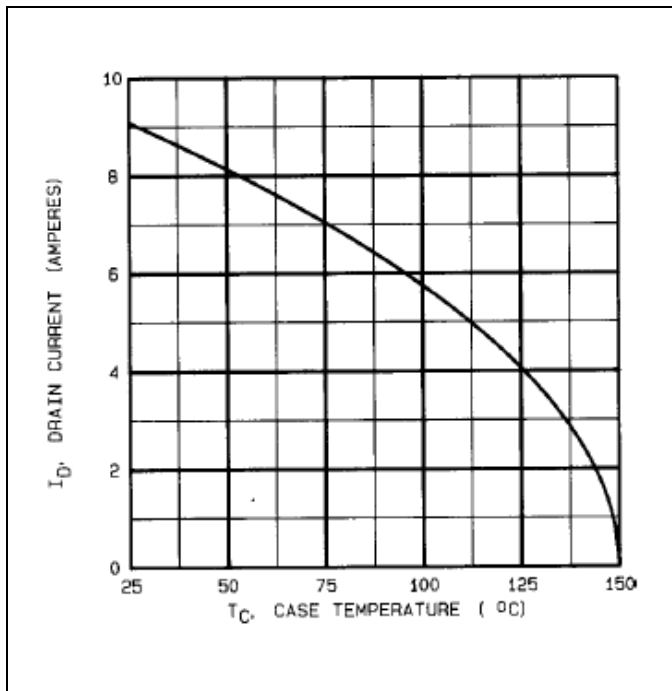

Figure 10 Maximum Drain Current Vs. Case Temperature

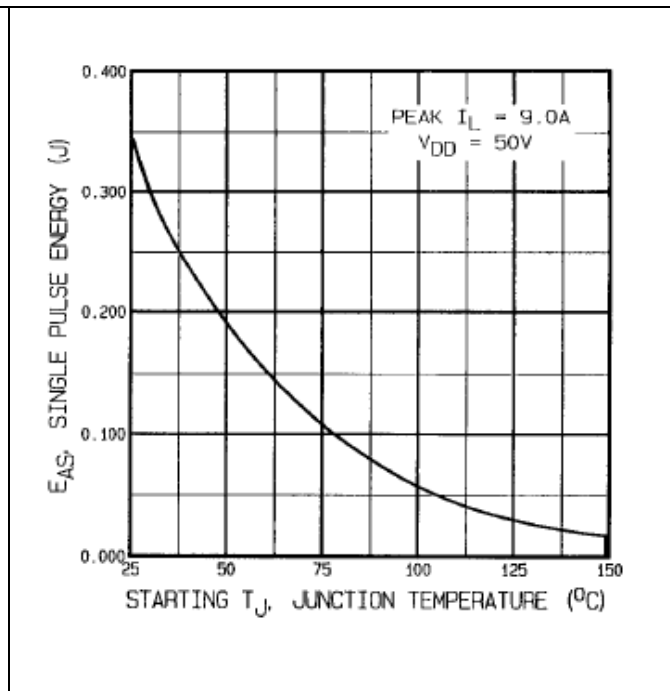

Figure 11 Maximum Avalanche Energy Vs. Junction Temperature

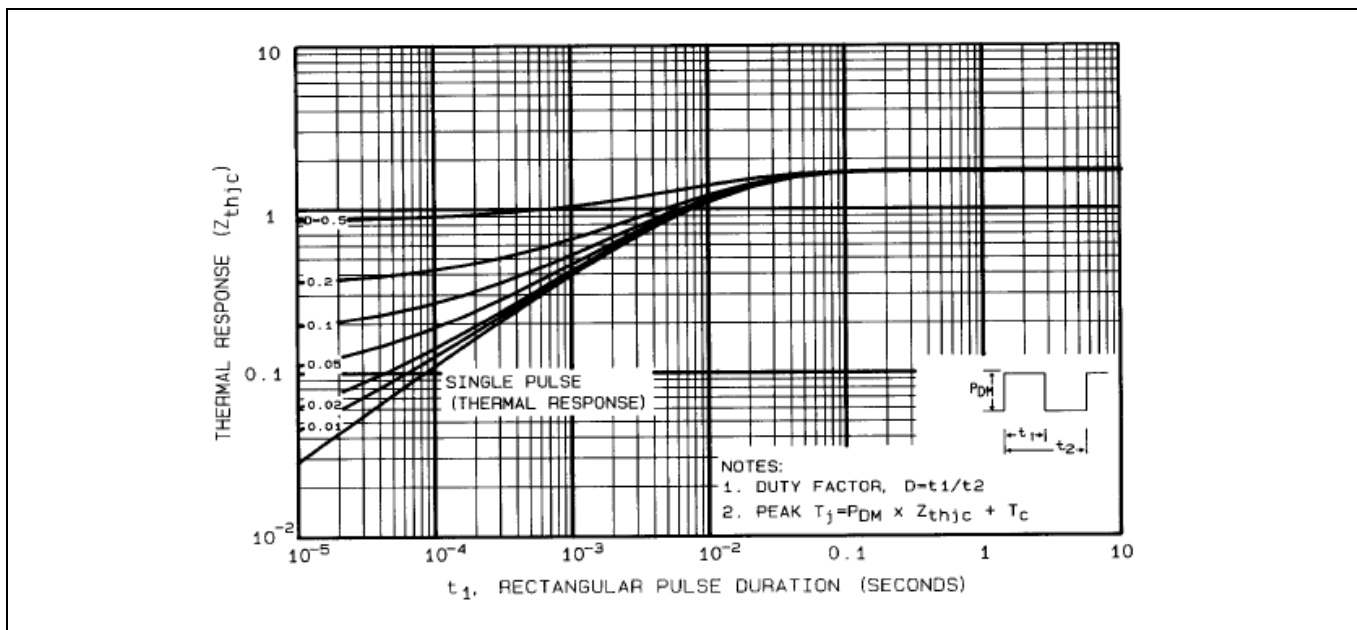

Figure 12 Maximum Effective Transient Thermal Impedance, Junction-to-Case

IRHN7230

Radiation Hardened Power MOSFET Surface-Mount (SMD-1)

Test Circuits (Pre-irradiation)

4 Test Circuits (Pre-irradiation)

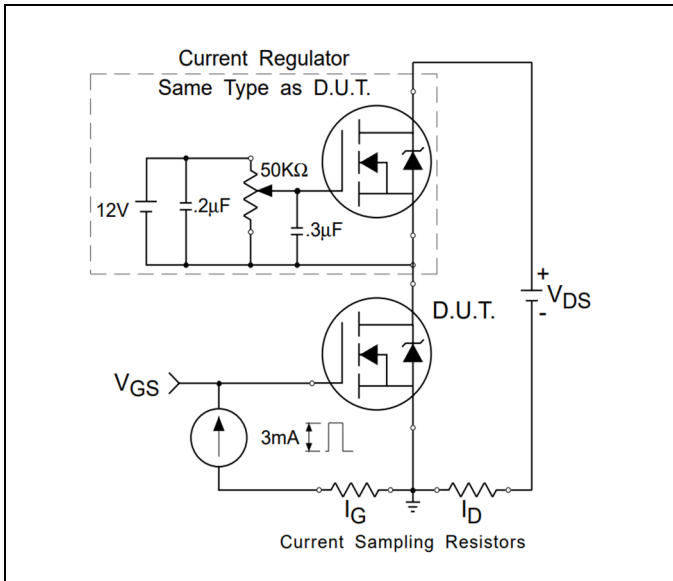

Figure 13 Gate Charge Test Circuit

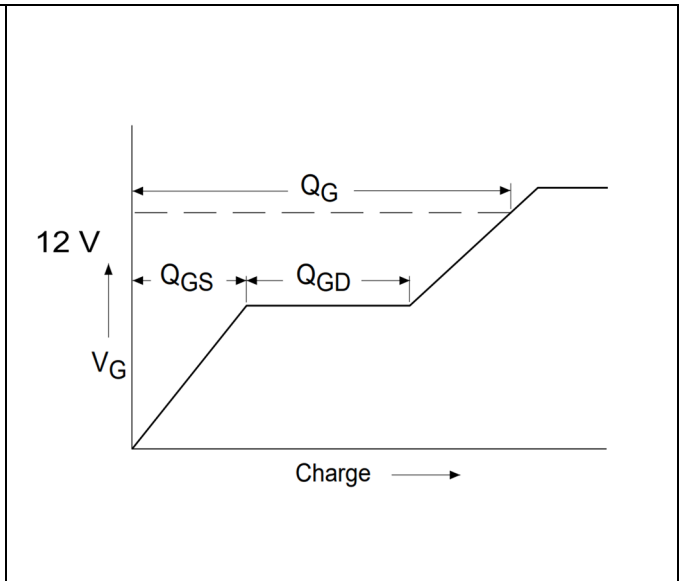

Figure 14 Gate Charge Waveform

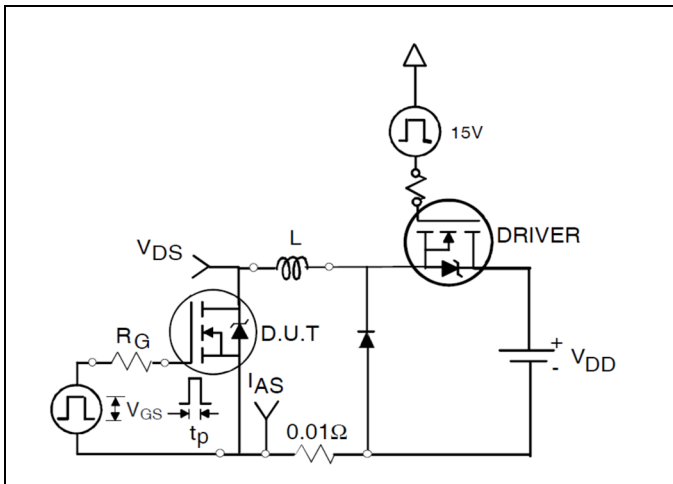

Figure 15 Unclamped Inductive Test Circuit

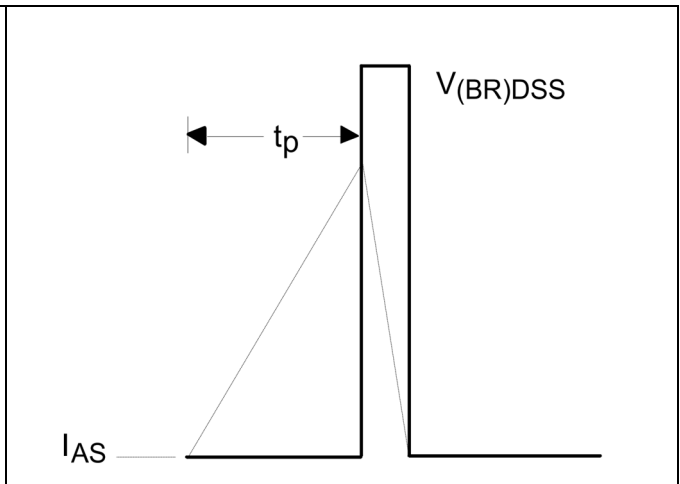

Figure 16 Unclamped Inductive Waveform

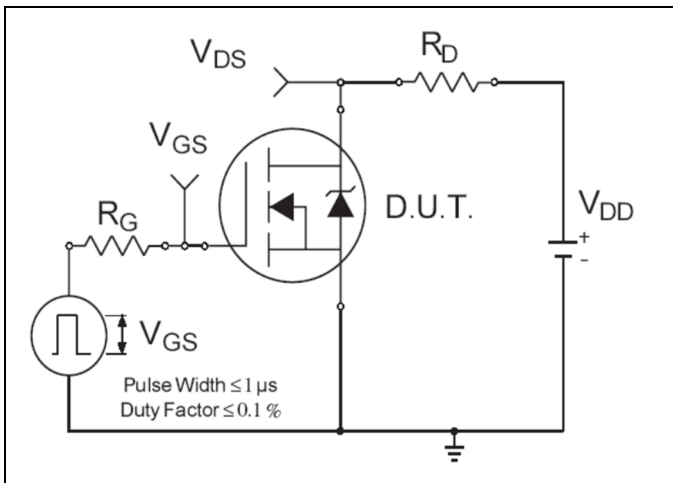

Figure 17 Switching Time Test Circuit

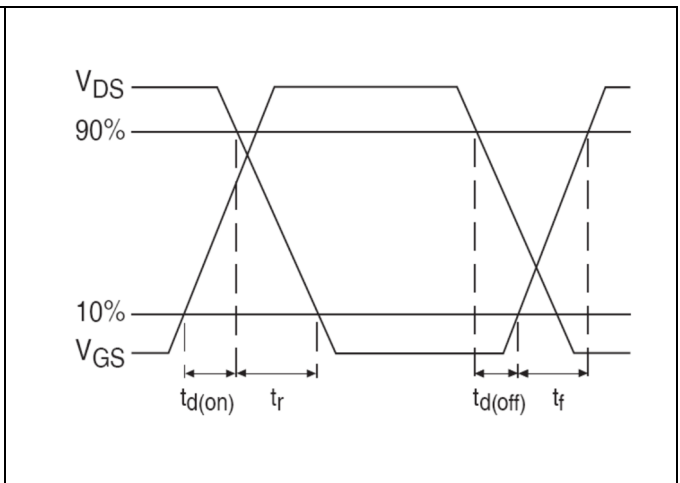
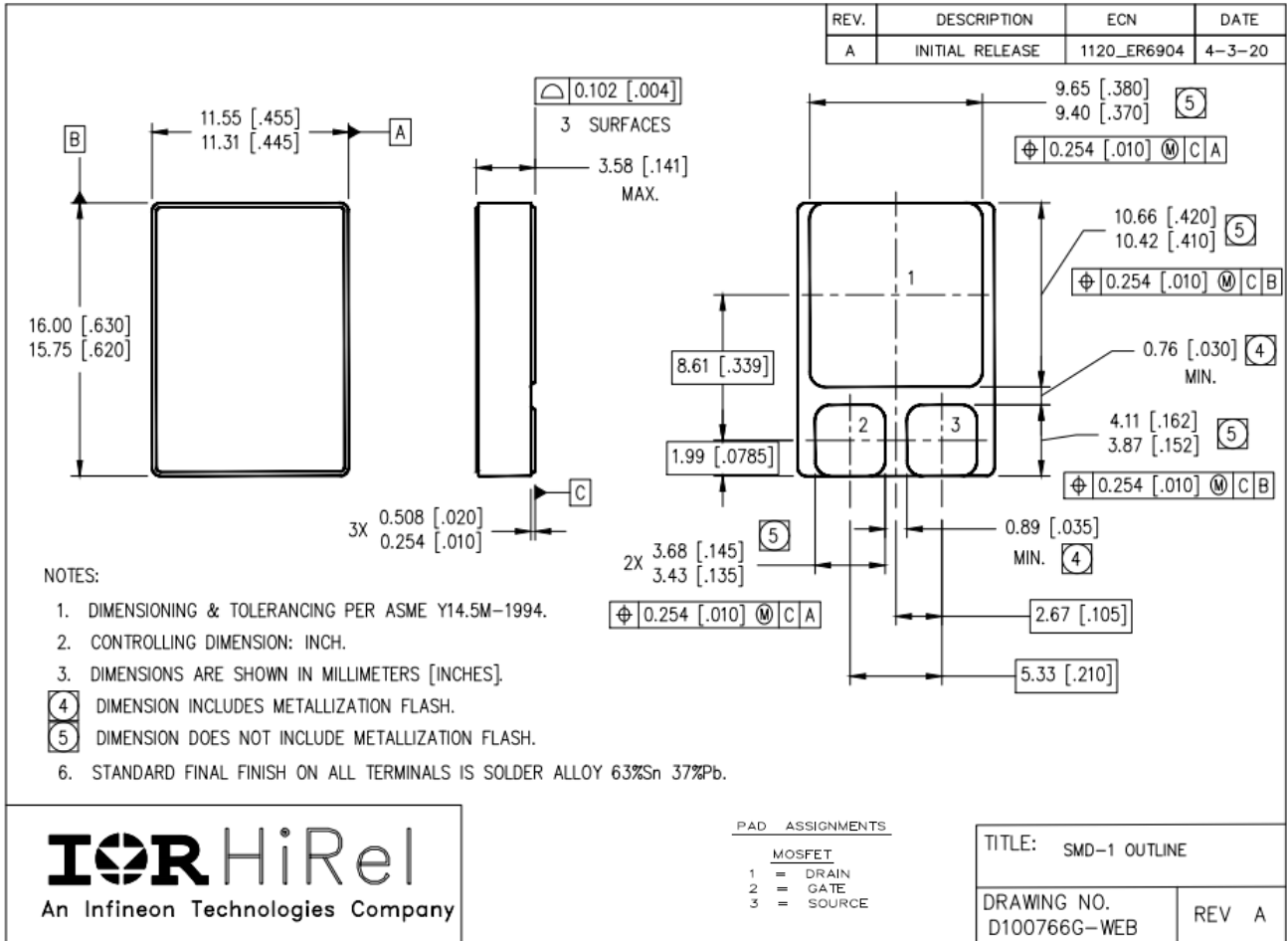

Figure 18 Switching Time Waveforms

Package Outline

5 Package Outline

Note: For the most updated package outline, please see the website: [SMD-1](#)



Revision history**Revision history**

Document version	Date of release	Description of changes
	09/23/1998	Datasheet (PD-90822B)
Rev C	06/22/2001	Updated Switch time –page2
Rev D	05/24/2022	Updated based on ECN-1120_09018

Trademarks

All referenced product or service names and trademarks are the property of their respective owners.

Edition 2022-05-24

Published by

**International Rectifier HiRel Products,
Inc.**

**An Infineon Technologies company
El Segundo, California 90245 USA**

**© 2022 Infineon Technologies AG.
All Rights Reserved.**

**Do you have a question about this
document?**

Email: erratum@infineon.com

Document reference

IMPORTANT NOTICE

The information given in this document shall in no event be regarded as a guarantee of conditions or characteristics ("Beschaffheitsgarantie").

With respect to any examples, hints or any typical values stated herein and/or any information regarding the application of the product, Infineon Technologies hereby disclaims any and all warranties and liabilities of any kind, including without limitation warranties of non-infringement of intellectual property rights of any third party.

In addition, any information given in this document is subject to customer's compliance with its obligations stated in this document and any applicable legal requirements, norms and standards concerning customer's products and any use of the product of Infineon Technologies in customer's applications.

The data contained in this document is exclusively intended for technically trained staff. It is the responsibility of customer's technical departments to evaluate the suitability of the product for the intended application and the completeness of the product information given in this document with respect to such application.

For further information on the product, technology, delivery terms and conditions and prices please contact your nearest Infineon Technologies office (www.infineon.com).

WARNINGS

Due to technical requirements components may contain dangerous substances. For information on the types in question please contact your nearest International Rectifier HiRel Products, Inc., an Infineon Technologies company, office.

International Rectifier HiRel Components may only be used in life-support devices or systems with the expressed written approval of International Rectifier HiRel Products, Inc., an Infineon Technologies company, if failure of such components can reasonably be expected to cause the failure of that life-support device or system, or to affect the safety and effectiveness of that device or system.

Infineon Technologies' products may not be used in any applications where a failure of the product or any consequences of the use thereof can reasonably be expected to result in personal injury.

Life support devices or systems are intended to be implanted in the human body, or to support and/or maintain and sustain and/or protect human life. If they fail, it is reasonable to assume that the health of the user or other persons may be endangered.