

## EV On-Board DC-DC Converter



### Features

- Constant current for battery charging applications
- Input reverse polarity protection
- CAN2.0B interface
- Bootloader via CAN bus
- IP67 enclosure, liquid cooled
- Full set of protections

### Absolute Maximum Rating

Excessive stresses over these absolute maximum ratings can cause damage to the converter. Operation should be limited to the conditions outlined under the Electrical Specification Section.

Parameter	Min	Max	Unit
Input Voltage (continuous)	-450	450	Vdc
Operating Temperature (case)	-40	85	°C
Storage Temperature	-55	125	°C

### Electrical Specifications

These specifications are valid over the converter's full range of input voltage, output voltage, output current, and operating temperature unless noted otherwise.

#### Input Specifications

Parameter	Min	Typical	Max	Unit
Input Voltage	250	350	410	Vdc
Input Current	-	-	10	A
Wakeup Bias Voltage (connected to the main output)	12	28	32	Vdc
Current Draw of Wakeup Bias (standby)	0.20	0.25	0.30	A
Current Draw of Wakeup Bias (normal operation)	0.40	0.45	0.50	A
ENABLE High	12	28	32	Vdc
ENABLE Low	0	1.0	1.5	Vdc

### Output Specifications

Parameter	Min	Typical	Max	Unit
Output Voltage Set Point (software adjustable)	18	28	32	Vdc
Output Current (software adjustable)	2	-	70	A
Output Voltage Set Point Accuracy (typical Vin; full load; Ta = 25°C)	-2	-	+2	%Vo
Output Voltage Set Point Accuracy (over all conditions)	-2	-	+2	%Vo
Output Ripple and Noise Voltage RMS	-	-	180	mVrms
Peak-to-Peak (5 Hz to 20 MHz bandwidth, typical Vin)	-	-	280	mVp-p
Output Power	-	-	2,000	W
Efficiency				
Typical Vin; 20% of full load, Ta = 25°C	-	92.0	-	%
Typical Vin; 50% of full load, Ta = 25°C	-	94.0	-	%
Typical Vin; 100% of full load, Ta = 25°C	-	93.0	-	%
Output Ripple Frequency	440	460	480	kHz
Dynamic Response (typical Vin; Ta = 25°C; load transient 0.1A/μs)				
Load step from 10% to 100% of full load:				
Peak deviation	-	5	-	%Vo
Settling time (to 10% band of Vo deviation)	-	2	-	ms
Load step from 100% to 10% of full load:				
Peak deviation	-	5	-	%Vo
Settling time (to 10% band of Vo deviation)	-	2	-	ms
Turn-on Time (from applying DC input to Vo=90%)	-	200	-	ms

### General Specifications

Parameter	Min	Typical	Max	Unit
Ingress Protection	IP67			
Isolation Capacitance	-	6,000	-	pF
Dimensions (not including terminals)	345.0 x 256.0 x 94.2			mm
Weight	-	6.0	-	Kg
Operating Humidity	5	-	95	%RH
On/Off DC-DC converter	CAN command			

### Cooling Specifications

Parameter	Description
Cooling Style	Liquid cooled, inlet liquid temperature less than 65°C
Coolant Medium/Mixture	50/50 Ethylene Glycol/Water
Coolant Flow (typical)	5L
Pressure Drop	See Appendix I

### Protection Specifications

Parameter	Notes	Min	Typical	Max	Unit
Input Under-voltage Protection		235	240	245	Vdc
Input Under-voltage Recovery	Auto-recovery	245	250	255	
Input Over-voltage Protection		415	420	425	
Input Over-voltage Recovery	Auto-recovery	405	410	415	
Output Over-voltage Protection		-	35	-	
Output Over-voltage Recovery	Auto-recovery	-	34	-	
Output Over-current Protection	Current limiting mode	-	70	-	A
Output Short Circuit Protection	Auto-recovery				
Over Temperature Protection		100	105	110	°C
Over Temperature Recovery	Auto-recovery	90	95	100	

### Safety Specifications

Parameter	Notes	Min	Typical	Max	Unit
Isolation Voltage	Input-Case, 1 minute, <5mA	2,000	-	-	Vac
Insulation Resistance	Input-Output, 1000Vdc, 90% RH, nominal air pressure	200	-	-	MΩ
	Input-Case, 1000Vdc, 90% RH, nominal air pressure	200	-	-	

Note: The negative output terminal is connected to Case.

### Communication Specifications

Parameter	Description
Interface	Based on CAN2.0B interface at 500Kbps baud rate
Protocol	NetPower standard protocol, detailed in CAN matrix: CD1XKX-28A-J1939-V3.0
Functions	Turn on/turn off DC-DC converter
	Set output voltage
	Set maximum input current limit
	Monitor real-time parameters (voltages, currents and temperature) and faults
	Bootload software

### Customization Specifications

Parameter	Description
Output Reverse Polarity Protection	Detect the polarity of the output terminal connection, if the connection is reversed, the DC-DC converter will be latched off
Parallel	Multiple DC-DC converters can operate in parallel to provide higher output power
CAN Communication Baud Rate	Choice of: 125kbps, 250kbps, 500kbps(default) or 1000kbps
UDS Diagnostic and Bootloader	ISO 14229 Road Vehicles—Unified Diagnostic Services(UDS) ISO 15765 Road Vehicles—Diagnostics on Controller Area Networks(CAN)
J1939 Communication, Diagnostic and Bootloader	SAE J1939-21 Data Link Layer SAE J1939-71 Vehicle Application Layer SAE J1939-73 Application Layer—Diagnostics SAE J1939-81 Network Management
Customized Protocol	According to customer requirements

## Interface Definitions

Connector	Connector Model	
	Connector PN	Mating Connector PN
Input Connector	2103124-4; 2-2141600-2; 928999-5	4-2103177-4; 1-968853-3; 1587828-3; 1587829-3; 1587826-3; 2103181-3
	Supplier: TE	
Output Connector	Positive: SLPIRBBPSR0EH (C10-738726-3100)	SLPIPB70BSR0EH (C10-738727-3700)
	Negative: SLPIRBBPSB0EH (C10-738726-2100)	SLPIPB70BSB0EH (C10-738727-2700)
	Supplier: Amphenol	
Signal Connector	LPT02SE-12-8P(023)(LC); LPTC-SF-20P-20-1; C10-101949-012	LPT06SE-12-8S(023)(LC); LPTC-SF-20S-20-1
	See "Signal Connector Descriptions"	

## Input Connector Descriptions

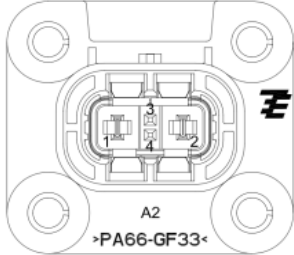
Pin	Name	Description	Model: 2103124-4; 2-2141600-2; 928999-5 Supplier: TE
1	Vin-	Input voltage -	
2	Vin+	Input voltage +	
3	HVIL+	High voltage interlock +	
4	HVIL-	High voltage interlock -	

Note: "HVIL+" and "HVIL-" are shorted together once the high voltage input cable is properly plugged in.

## Signal Connector Descriptions

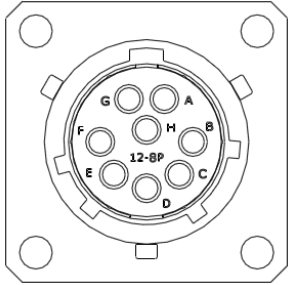
Pin	Name	Description	Model: LPT02SE-12-8P(023)(LC); LPTC-SF-20P-20-1; C10-101949-012 Supplier: Amphenol
A	ENABLE	Enable DC-DC converter	
B	HVIL+	High voltage interlock +	
C	HVIL-	High voltage interlock -	
D	12V+	External bias input+, connected to 12V+	
E	NC	No connection	
F	12V-	External bias input-, connected to 12V-	
G	CAN_H	CAN high	
H	CAN_L	CAN low	

Note: "HVIL+" and "HVIL-" are output signals that are internally connected with "HVIL+" and "HVIL-" in the input connector respectively.



## Mechanical Drawing

Unit: mm

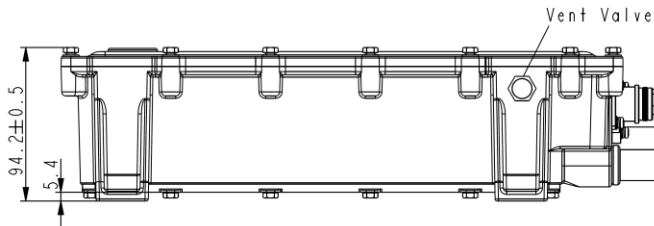
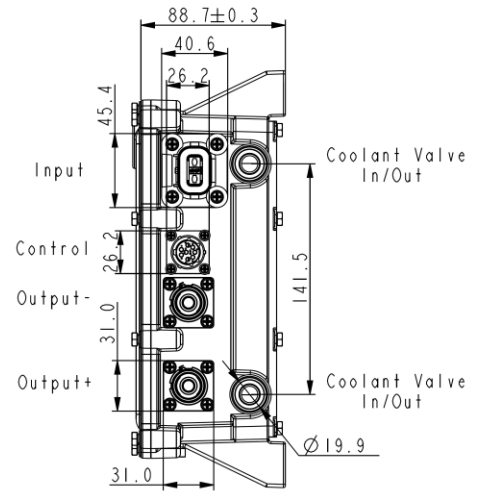
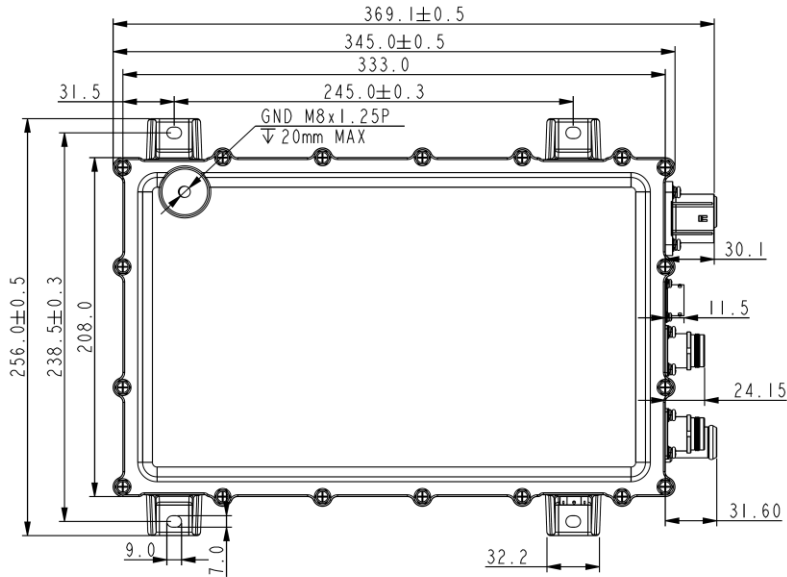



## Appendix I

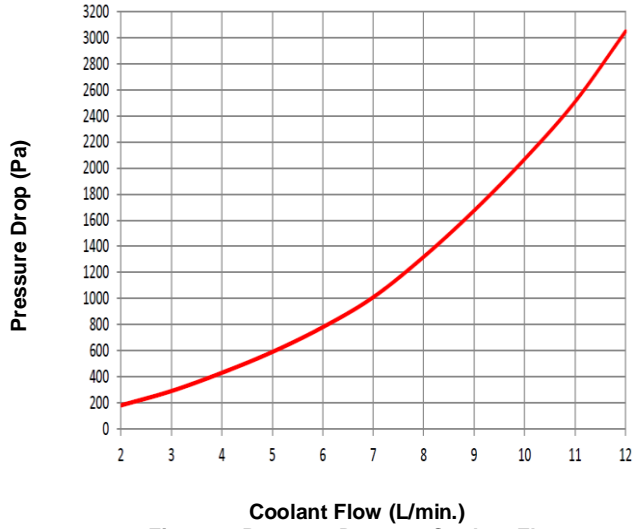

Figure 1. Pressure Drop vs. Coolant Flow